

Table of content

Flexible suspension

1.1	General	Page	2
1.2	Flexible stabilizers	Page	3
1.3	Hanging fixed points	Page	4
1.4	Standing fixed points	Page	5

Stainless steel bellows

2.1	General	Page	6
2.2	Flanges type DIN 2573 PN6	Page	8
2.3	Flanges type DIN 2576 PN10	Page	9
2.4	Flanges type DIN 86044	Page	10

Other exhaust equipment

3.1	Funnel deck piperuns	Page	11
3.2	Heat reducing bulkhead penetration	Page	12
3.3	Heat reducing flexible bulkhead penetration	Page	13

1.1 General

In every situation where diesel engines are used, noise and vibration will be generated! As well through the engine foundation, engine disturbance will travel along the exhaust system to be transmitted into the vessel wherever the system is in contact with the ship's structure. Rubber Design BV has the experience and solutions to control the vibration and noise emissions from the exhaust system.

By flexibly mounting not only the engine but also the exhaust system, we can control most of these unwanted noise emissions. A significant reduction in the radiated noise and vibration can be achieved by introducing rubber-metal elements between the exhaust system and ship's structure.

For an explanation of how the noise reduction is achieved, the transmission speed of sound through steel and rubber needs to be understood. The transmission speed through steel is approximately 5000 m/sec. while through rubber, the transmission speed is approximately 45 to 90 m/sec.

By careful design and positioning of the rubber-metal elements it is possible to obtain a reduction of 8 to 10 dB (A) across the majority of the frequency range of 63 to 4000 Hz.

To give the optimum isolation, the number of mountings are kept to a minimum and positioned at strengthened locations in the ship's structure, for example deck levels, frame webs or specially constructed supports. Every installation takes into account the weight of the appropriate section of the system, the forces produced by ship movements and thermal expansion effects.

It is equally important to ensure the frequencies, produced by any part of the exhaust system, are not the same as the frequencies caused by the engine ignition, the first order frequencies of the engine or the propeller blade frequency.

Types of mounting.

Two basic types of mounting are used, fixed support mountings and stabiliser mountings. The fixed support mountings take the static and dynamic forces and determine the direction of the expansion in the exhaust system. The stabiliser mountings allow the thermal expansion movement caused by the high temperature of the exhaust piping within the ship's structure to be controlled. In case of horizontal piping the stabiliser mountings also carry the weight of the pipe.

Thermal insulation.

In order to protect the rubber against the high exhaust gas temperatures, it is necessary to install sufficient thermal insulation. It is essential to reduce the temperatures at the rubber-metal elements to less than 80°C. By using suitable insulation materials, it is possible to keep the temperature to a maximum of 50°C. It is always recommended to provide a minimum air gap of approximately 25 mm between the exhaust mounting and exhaust system. The above is applicable for the flexible fixed points, for the stabilisers the thermal insulation is attained to the length of the threaded rod.



1.3 Hanging fixed points

The hanging fixed points support the exhaust system and control the dynamic forces which occur in the system while the vessel is in operation.

The fixed points control the direction of the thermal expansion within the exhaust system.

The hanging fixed points are available in the following dimensions:

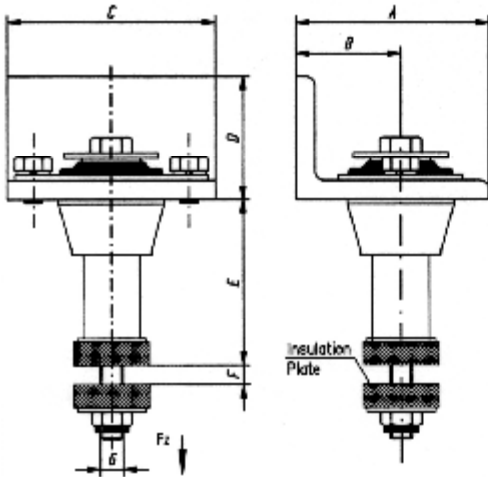

RD 101 / RD 251 / RD 501

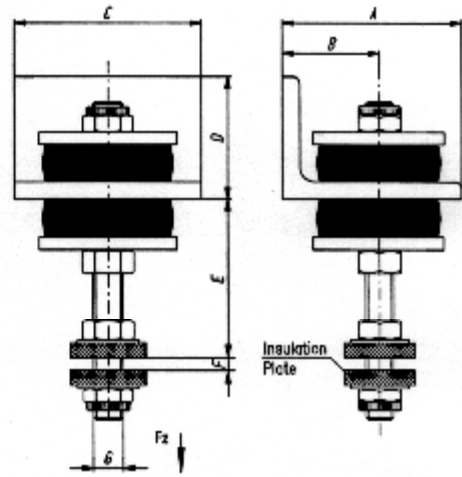

RD 251D / RD 501D / RD 1001 / RD 2001 / RD 3001

Type	A	B	C	D	E	F	G	Insulation plate	Weight	Fz max	Hardness
RD 101	75	40	95	50	50	Max.20	M10	35x35x12	0.9 kg	900 N	45° / 60°
RD 251	100	55	110	65	88	Max.15	M12	40x40x12	2.1 kg	5200 N	45° / 60° / 70°
RD 251D	100	55	100	65	105	-	M12	40x40x12	1.9 kg	3000 N	45° / 60°
RD 501	120	68	135	80	97	Max.20	M16	50x50x12	3.8 kg	9500 N	45° / 60° / 70°
RD 501D	120	65	120	80	100	-	M16	50x50x12	3.5 kg	4500 N	45° / 60°
RD 1001	150	80	150	100	130	-	M24	60x60x12	7.3 kg	9000 N	45° / 60°
RD 2001	200	110	180	100	130	-	M30	70x70x16	10.1 kg	20000 N	45° / 65°
RD 3001	200	110	230	100	155	-	M36	80x80x16	17.0 kg	34000 N	45° / 65°



1.4 Standing fixed points

The standing fixed points support the exhaust system and control the dynamic forces, which occur in the system while the vessel is in operation.

The fixed points control the direction of the thermal expansion within the exhaust system.

The standing fixed points are available in the following dimensions:

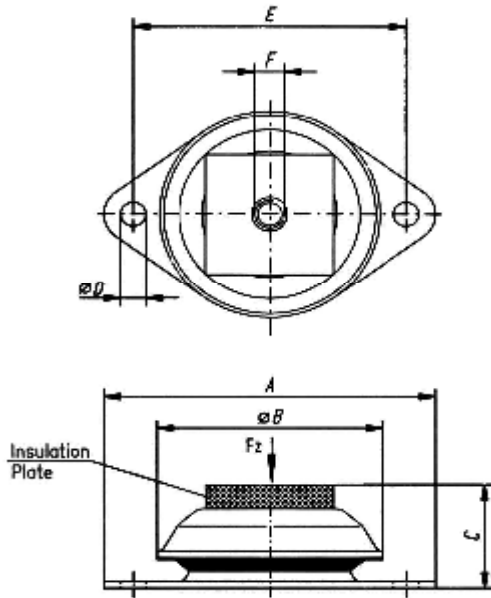

RD MP 2 / RD MP 3

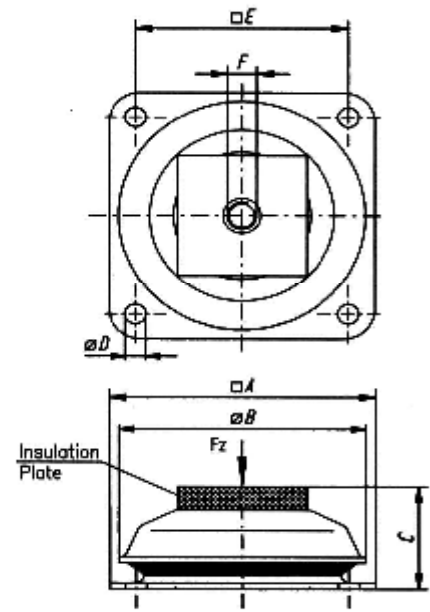

RD MP 4 / RD MP 5

Type	A	B	C	D	E	F	Insulation Plate	Weight	Fz max	Hardness
RD MP 2	134	82	45	11 (2x)	100	M12	40x40x12	0.5 kg	2250 N	45° / 55° / 65°
RD MP 3	170	113	55	13 (2x)	140	M12	40x40x12	1.1 kg	4750 N	45° / 55° / 65°
RD MP 4	168	150	66	13 (4x)	132	M16	80x80x12	2.2 kg	14000 N	45° / 55° / 65°
RD MP 5	220	206	94	18 (4x)	180	M20	100x100x20	5.4 kg	36000 N	45° / 55° / 65°



2.1 Stainless steel exhaust bellows

There are two basic types of expansion bellows – singles and doubles, and their purpose is to absorb the movement in any pipework run that is fixed between two fixed points.

Single bellows units are chiefly used to absorb axial movement, while double units are more suitable where lateral movement is present.

To move a bellows in any direction a force must be applied. That force is the product of the movement and the spring rate of the bellows in the direction of the movement.

Rubber Design supplies a stainless steel bellows with a low stiffness, which achieves in combination with our flexible suspension the best

control of vibrations and forces in pipe systems which provides optimal lifetime.

We can deliver bellows with welding ends or flanges. Standard we can supply flanges like DIN 86044, DIN PN 6/10. (For measurements see attached flange tables), if required we are able to deliver other types of flanges e.g. JIS 5K and ANSI 150 LBS or a flange especially made in accordance with your desires. It is also possible to deliver the stainless steel bellows with a rotating flange to simplify assembling.

Single bellows

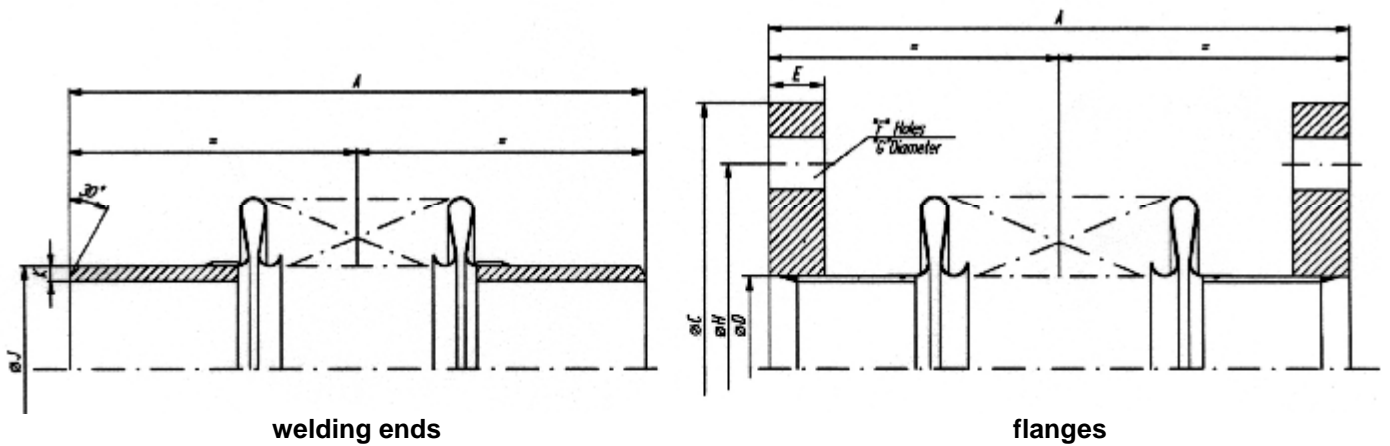

N.B.	050	065	080	100	125	150	200	250	300	350	400	450	500	600	700	800	900	1000
A	195	210	250	290	305	305	310	320	320	330	340	340	340	350	350	350	360	360
J	60	76	89	114	140	168	219	273	324	356	406	457	508	608	-	-	-	-
K	4.5	4.5	4.5	4.5	5.6	5.6	5.6	6.3	6.3	6.3	6.3	6.3	6.3	6.3	-	-	-	-
Max axial	35	38	32	32	32	32	32	40	40	40	64	64	64	64	64	64	64	64
Max lat.	18	16	22	28	22	20	16	17	15	14	13	11	10	9	7.5	7	6	5.5

On page 12, 13, and 14 you can find the dimensions of the standard flanges.

Combined movements at reduced rates.



Cold-pull

Bellows are designed for both compression and extension from their natural or "free length." By pre-setting (or 'cold-pulling') the bellows length prior to installation we are able to take full advantage of the available movement. Maximum performance is obtained by allowing movement to be taken equally either side of the free length position. The mentioned movements for the bellows unit must not be exceeded.

Transit bars

Some means of length restriction will be added to the bellows unit before shipment in order to maintain the overall length at its' factory setting. These may be threaded bars, angle iron or wood blocks. These must be removed after installation in order for the bellows unit to function correctly.

Twin bellows

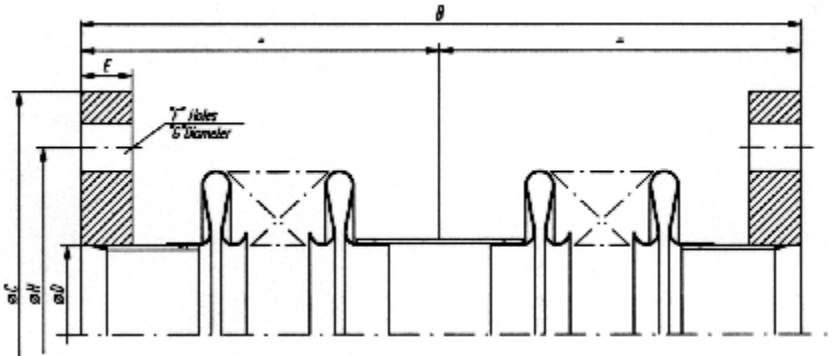

N.B.	080	100	125	150	200	250	300	350	400	450	500	600	700	800	900	1000
B	400	400	400	500	500	500	500	500	600	600	600	600	600	600	600	600
Max axial	80	69	70	75	75	55	64	64	90	90	90	90	90	90	90	90
Max lat.	35	40	60	70	70	32	43	39	75	69	62	52	45	39	35	31

On page 12, 13, and 14 you can find the dimensions of the standard flanges.
Combined movements at reduced rates

Rubber Design can also deliver counterflanges complete with an exhaust-gasket and a set of nuts, bolts and washers. All kinds of flanges are possible and the gaskets are of high quality Steamgard 500.

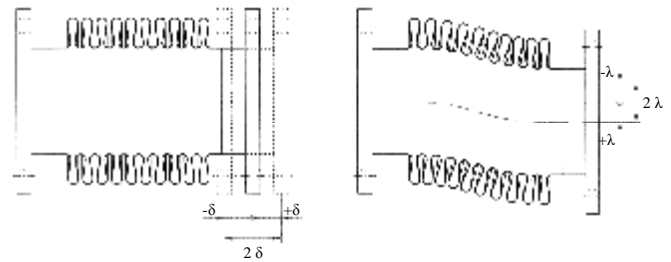

To calculate the maximal axial and lateral movement you can use the following formula.

$$\frac{d_{\max} - d}{d_{\max}} \times l_{\max} = l$$

$$\frac{l_{\max} - l}{l_{\max}} \times d_{\max} = d$$

- δ_{\max} = Maximal axial movements.
- δ = Existing axial movements.
- λ_{\max} = Maximal lateral movements.
- λ = Existing lateral movements.

2.2 Flanges type DIN 2573 PN6 with reduced thickness.

Tooling: Inner-, outer- and gasketside rolled.
 Provided with three gasketgrooves.

Material: Rst. 37-2 or stainless steel.

N.B.	Outside diameter (C)	Inside diameter (D)	Thickness (E)	Number of holes (F)	Diameter of the holes (G)	Pitch circle diameter (H)	Weight (steel)
050	140	61	12	4	14	110	1,1 kg
065	160	77	12	4	14	130	1,4 kg
080	190	90	12	4	18	150	2,0 kg
100	210	116	12	4	18	170	2,2 kg
125	240	142	16	8	18	200	3,4 kg
150	265	171	16	8	18	225	3,8 kg
175	295	195	16	8	18	255	4,5 kg
200	320	222	16	8	18	280	5,0 kg
250	375	276	16	12	18	335	5,9 kg
300	440	327	16	12	22	395	7,9 kg
350	490	360	16	12	22	445	10,3 kg
400	540	411	16	16	22	495	11,3 kg
450	595	461	16	16	22	550	13,1 kg
500	645	512	16	20	22	600	14,1 kg
600	755	614	24	20	26	705	22,0 kg
700	860	716	24	24	26	810	25,8 kg
800	975	818	24	24	30	920	31,8 kg
900	1075	920	24	24	30	1020	35,2 kg
1000	1175	1022	24	28	30	1120	38,1 kg

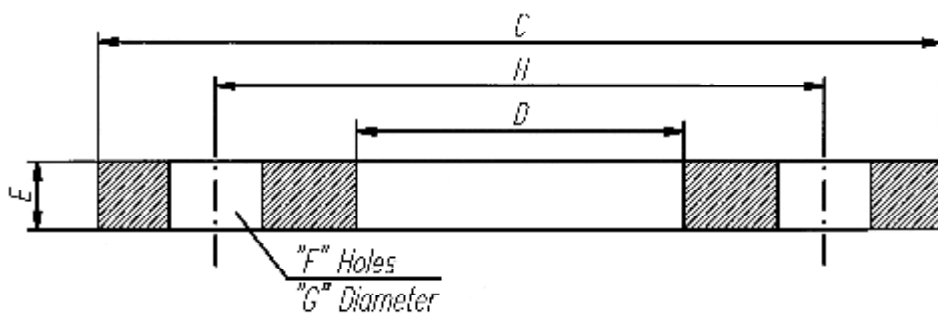

2.3 Flanges type DIN 2576 PN10 with reduced thickness.

Tooling: Inner-, outer- and gasketside rolled.
 Provided with three gasketgrooves.

Material: Rst. 37-2 or stainless steel.

N.B.	Outside diameter (C)	Inside diameter (D)	Thickness (E)	Number of holes (F)	Diameter of the holes (G)	Pitch circle diameter (H)	Weight (steel)
050	165	61	12	4	18	125	1,6 kg
065	185	77	12	4	18	145	2,0 kg
080	200	90	12	8	18	160	2,2 kg
100	220	116	12	8	18	180	2,4 kg
125	250	142	16	8	18	210	3,9 kg
150	285	171	16	8	22	240	4,7 kg
175	315	196	16	8	22	270	5,6 kg
200	340	222	16	8	22	295	6,1 kg
250	395	276	16	12	22	350	7,3 kg
300	445	328	16	12	22	400	8,3 kg
350	505	360	16	16	22	460	14,4 kg
400	565	411	16	16	26	515	17,1 kg
450	615	462	16	20	26	565	18,5 kg
500	670	514	16	20	26	620	21,0 kg
600	780	614	24	20	30	725	26,1 kg
700	895	716	24	24	30	840	32,7 kg
800	1015	818	24	24	33	950	41,0 kg
900	1115	920	24	28	33	1050	44,9 kg
1000	1230	1020	24	28	36	1160	53,4 kg

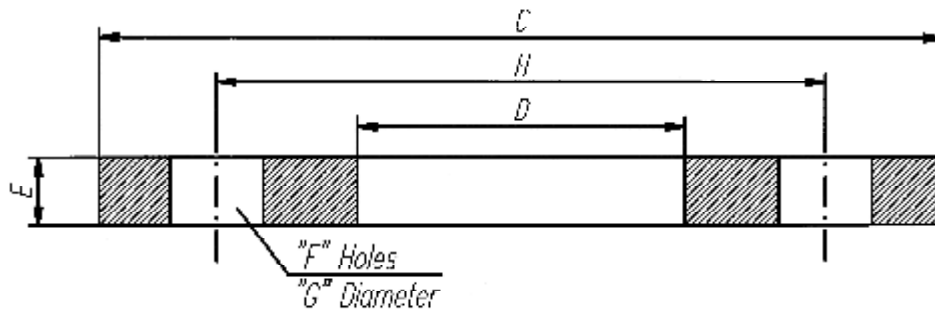

2.4 Flanges type DIN 86044

Tooling: Inner-, outer- and gasketside rolled.
Provided with three gasketgrooves.

Material: Rst. 37-2 or stainless steel.

N.B.	Outside diameter (C)	Inside diameter (D)	Thickness (E)	Number of holes (F)	Diameter of the holes (G)	Pitch circle diameter (H)	Weight (steel)
050	165	61	12	4	18	125	1,6 kg
065	185	77	12	4	18	145	2,0 kg
080	200	90	12	8	18	160	2,2 kg
100	220	116	12	8	18	180	2,4 kg
125	250	142	16	8	18	210	3,9 kg
150	285	171	16	8	22	240	4,7 kg
200	320	222	16	8	18	280	5,0 kg
250	375	276	16	12	18	335	5,9 kg
300	440	327	16	12	22	395	7,9 kg
350	490	360	16	12	22	445	10,3 kg
400	540	411	16	16	22	495	11,3 kg
450	595	461	16	16	22	550	13,1 kg
500	645	512	16	20	22	600	14,1 kg
550	703	563	20	20	22	650	20,5 kg
600	754	614	20	20	22	700	22,3 kg
650	805	665	20	20	22	750	24,0 kg
700	856	716	20	24	22	800	25,5 kg
750	907	767	20	24	22	860	27,3 kg
800	958	818	20	24	22	900	29,0 kg
900	1060	920	20	28	22	1010	32,3 kg
950	1110	970	20	28	22	1060	34,0 kg
1000	1162	1022	20	32	22	1110	35,6 kg
1100	1266	1126	20	32	22	1210	39,1 kg
1200	1366	1226	20	36	22	1310	42,3 kg
1300	1466	1326	20	40	22	1410	45,5 kg
1400	1566	1426	20	40	22	1510	48,9 kg
1500	1666	1526	20	44	22	1610	52,1 kg

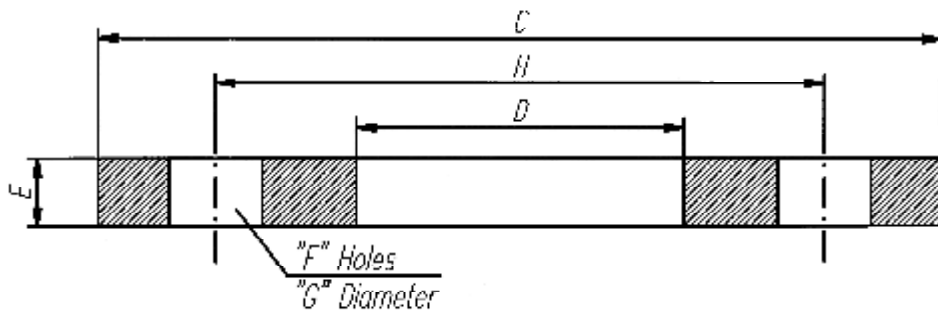

3.1 Funnel deck piperun

Funnel deck piperuns are meant to lead the exhaust gas pipe through the funnel deck. Due to the stainless steel cushions, the exhaust gas pipe can move in axial direction but is still flexible mounted.

The raincap protects the interior of the ship against rainwater and is made of stainless steel.

The piperuns are available in the following dimensions:

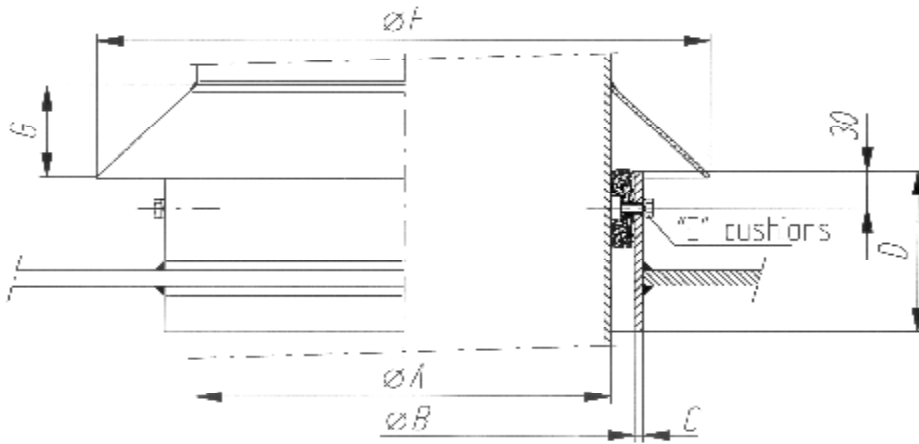

N.B.	A	B	C	D	E	F	G	Weight
050	60.3	109.8	5.6	130	2	215	75	3.5 kg
065	76.1	127.1	6.3	130	2	230	75	4.0 kg
080	88.9	136.0	5	130	3	240	75	4.0 kg
100	114.3	161.0	5	130	3	265	75	4.5 kg
125	139.7	187.0	6	130	3	290	75	6.0 kg
150	168.3	215.0	8	160	3	318	75	9.5 kg
200	219.1	266.0	8	160	3	369	75	11.0 kg
250	273.0	320.0	8	160	3	423	75	13.0 kg
300	323.9	370.0	8	160	4	474	75	15.0 kg
350	355.6	402.0	8	200	4	506	75	20.0 kg
400	406.4	453.0	8	200	4	556	75	22.5 kg
450	457.2	505.0	8	200	5	607	75	25.5 kg
500	508.0	555.0	8	200	5	658	75	27.5 kg
600	608.0	655.0	8	200	5	758	75	32.0 kg
700	711.0	758.0	8	200	5	862	75	37.0 kg
800	813.0	860.0	8	200	8	970	75	42.5 kg
900	914.0	961.0	8	200	8	1065	75	47.0 kg
1000	1016.0	1063.0	8	200	8	1173	75	52.5 kg

Larger sizes on request.



3.2 Heat reducing bulkhead penetration

Heat reducing bulkhead penetrations are especially designed to lead the exhaust gas pipe watertight through bulkheads or decks. By using special insulation material, we prevent the heat from flowing into the ship's structure. These bulkhead penetrations are designed with (relatively) small dimensions, therefore providing better and easier built-in possibilities.

Rubber Design delivers the heat reducing bulkhead penetration completely. This means that type 1 can easily be assembled by welding the bulkhead flange to the ship's structure. The threaded holes simplify the final assembly. Type 2 also enables it to easily disassemble the exhaust pipe afterwards.

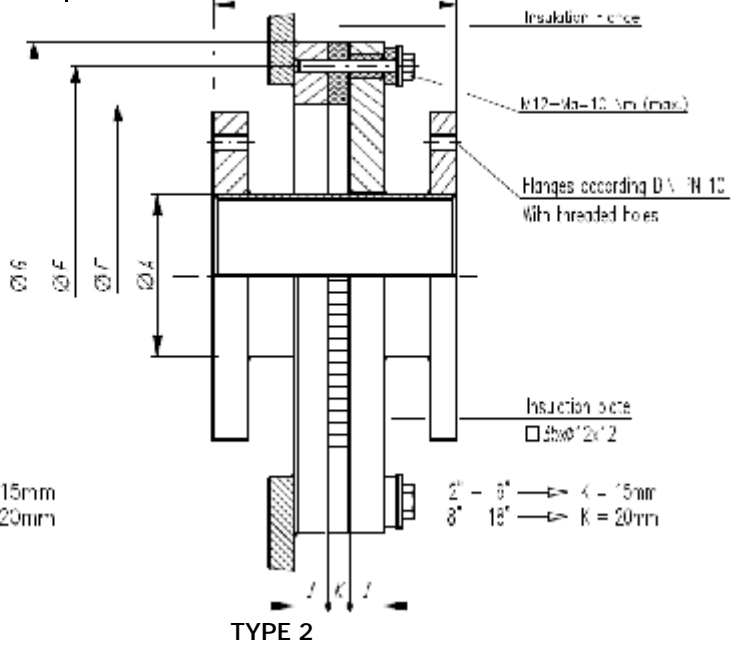
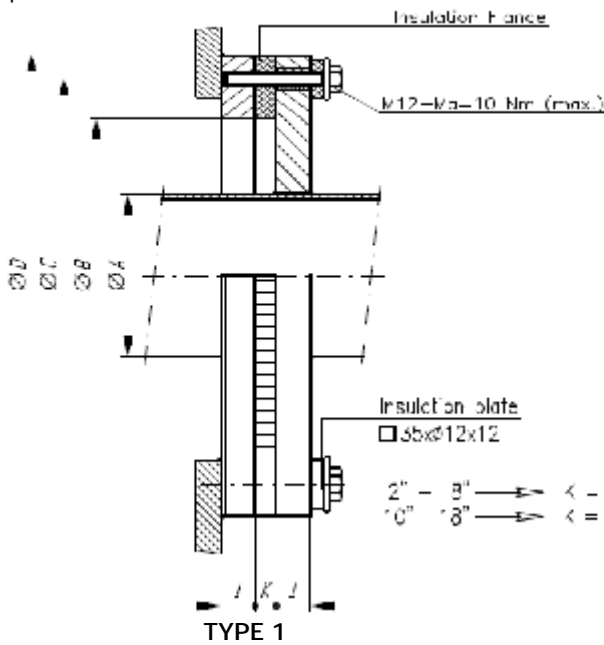

N.B.	A	B	C	D	E	F	G	H	I	Bolts for Type 1	Bolts for Type 2
050	60.3	171	240	285	171	240	285	180	16	M12 x 55 (8x)	M12 x 55 (8x)
065	76.1	171	240	285	222	295	340	180	16	M12 x 55 (8x)	M12 x 55 (8x)
080	88.9	171	240	285	222	295	340	200	16	M12 x 55 (8x)	M12 x 55 (8x)
100	114.3	171	240	285	222	295	340	200	16	M12 x 55 (8x)	M12 x 55 (8x)
125	139.7	196	270	315	276	350	395	200	16	M12 x 55 (8x)	M12 x 55 (12x)
150	168.3	222	295	340	327	395	440	200	16	M12 x 55 (8x)	M12 x 55 (12x)
200	219.1	276	350	395	355	445	490	200	16	M12 x 55 (12x)	M12 x 60 (12x)
250	273.0	327	395	440	411	495	540	200	16	M12 x 60 (12x)	M12 x 60 (16x)
300	323.9	411	495	540	461	550	595	200	16	M12 x 60 (16x)	M12 x 60 (16x)
350	355.6	411	495	540	512	600	645	200	16	M12 x 60 (16x)	M12 x 60 (20x)
400	406.4	461	550	595	614	700	754	200	16	M12 x 60 (16x)	M12 x 60 (20x)
450	457.2	512	600	645	614	700	754	200	16	M12 x 60 (20x)	M12 x 60 (20x)

Other dimensions on request.



3.3 Heat reducing flexible bulkhead penetration

Heat reducing flexible bulkhead penetrations are especially designed to lead the exhaust gas pipe watertight and flexible through bulkheads or decks. The rubber parts prevents the vibrations to move from the exhaust gas pipe into the ship's structure.

By using special insulation material, we avoid that the heat from the exhaust gas pipe will flow into the rubber parts. Rubber Design delivers the heat reducing flexible bulkhead penetration completely. The penetrations are available in the following dimensions.

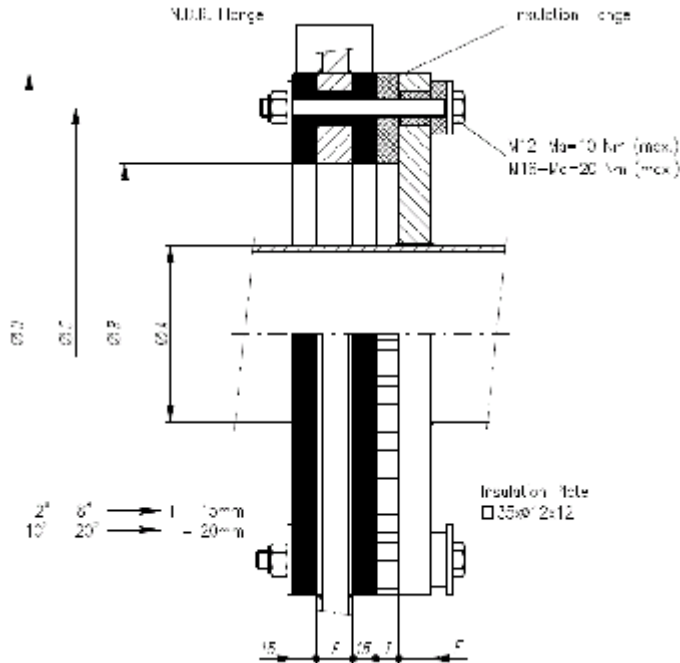

N.B.	A	B	C	D	E	Bolts	Weight
050	60.3	171	240	285	16	M12 x 110 (8x)	17 kg
065	76.1	171	240	285	16	M12 x 110 (8x)	16 kg
080	88.9	196	270	315	16	M12 x 110 (8x)	21 kg
100	114.3	222	295	340	16	M12 x 110 (8x)	24 kg
125	139.7	222	295	340	16	M12 x 110 (8x)	23 kg
150	168.3	276	350	395	16	M12 x 110 (12x)	29 kg
175	193.7	276	350	395	16	M12 x 110 (12x)	28 kg
200	219.1	327	395	440	16	M12 x 110 (12x)	32 kg
250	273.0	360	445	490	16	M12 x 120 (12x)	36 kg
300	323.9	411	495	540	16	M12 x 120 (16x)	40 kg
350	355.6	461	550	595	16	M12 x 120 (16x)	45 kg
400	406.4	512	600	645	16	M12 x 120 (20x)	54 kg
450	457.0	614	700	754	16	M12 x 120 (20x)	65 kg
500	508.0	614	700	754	16	M12 x 120 (20x)	61 kg

Other dimensions on request.

