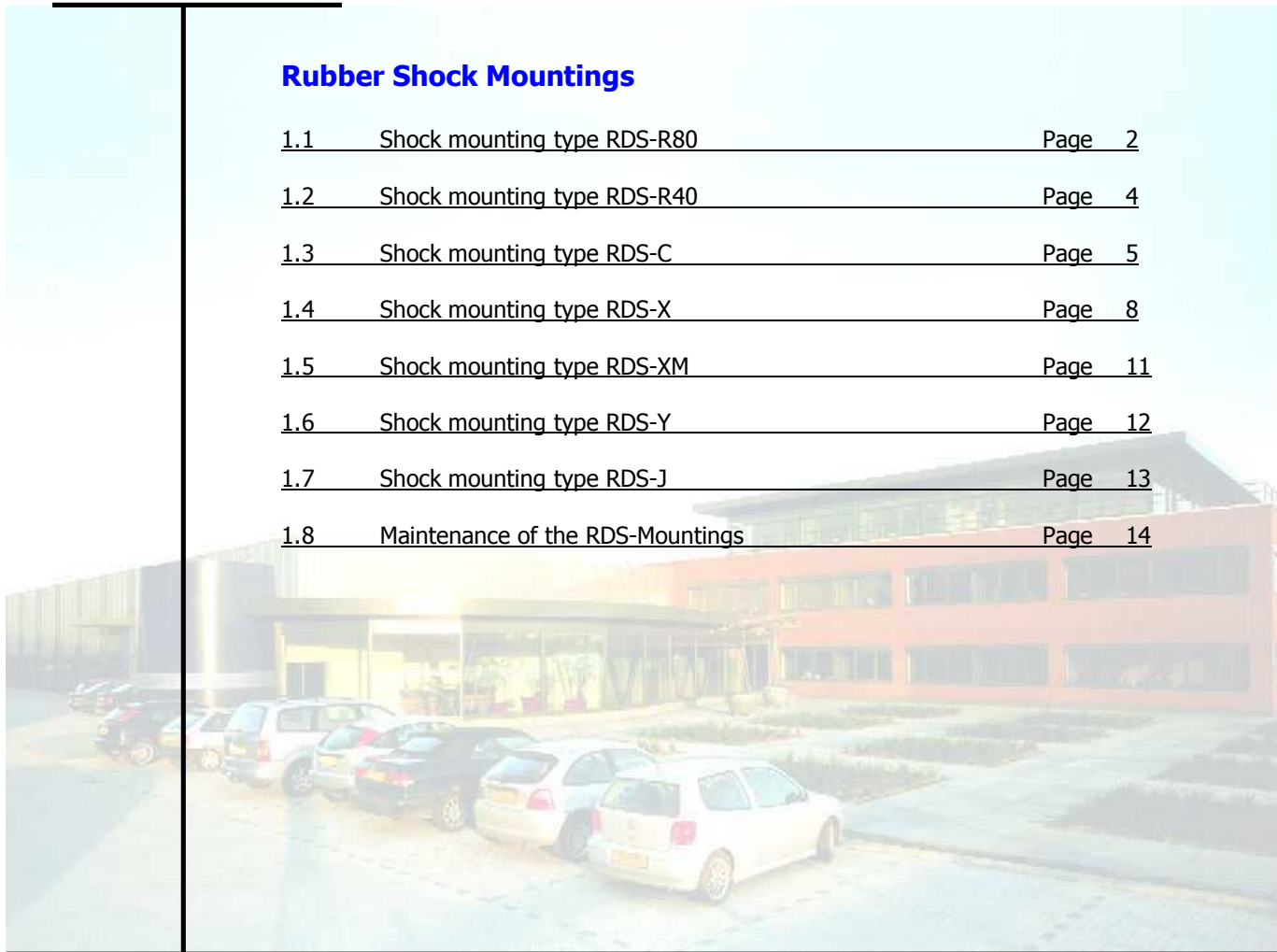

Table of content

Rubber Shock Mountings

<u>1.1</u>	Shock mounting type RDS-R80	Page 2
<u>1.2</u>	Shock mounting type RDS-R40	Page 4
<u>1.3</u>	Shock mounting type RDS-C	Page 5
<u>1.4</u>	Shock mounting type RDS-X	Page 8
<u>1.5</u>	Shock mounting type RDS-XM	Page 11
<u>1.6</u>	Shock mounting type RDS-Y	Page 12
<u>1.7</u>	Shock mounting type RDS-J	Page 13
<u>1.8</u>	Maintenance of the RDS-Mountings	Page 14



1.1 Shock mounting type RDS-R80

Rubber Design developed this shock mounting mainly for marine applications. This type of mounting can stand a linear shock deflection up to 80 mm. The RDS mounting is meeting the requirements of all international shock specifications such as BV 043, BV 044, MIL 901, STANAG and MOD.

The shock mounting type RDS is in particular suitable for marine applications such as propulsion engines, diesel generator sets and auxiliary equipment where attenuation of low frequencies is required.

The RDS shock mounting is capable to reduce an input shock of 210 G to a transmitted shock of 6 G in a time to maximum velocity of 5 ms.

The RDS shock mounting is suitable for a nominal load of 23 kN and a maximum load of 34 kN, resulting in a natural frequency of 4 Hz under maximum load.

The RDS shock mounting developed by Rubber Design with a shock deflection of 80 mm gives that extra shock insulation which makes the difference. Where others with the same unloaded mounting height are restricted to 60 mm shock deflection, Rubber Design operates at 80 mm.

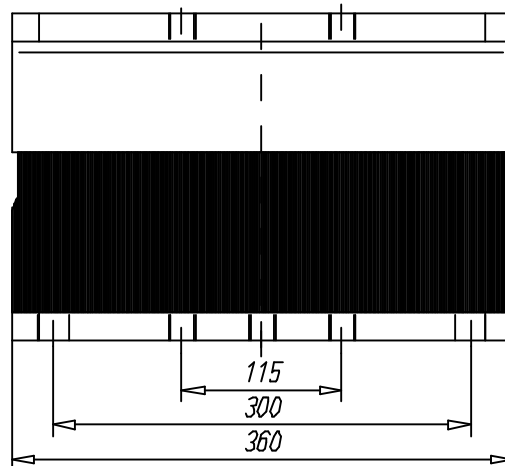
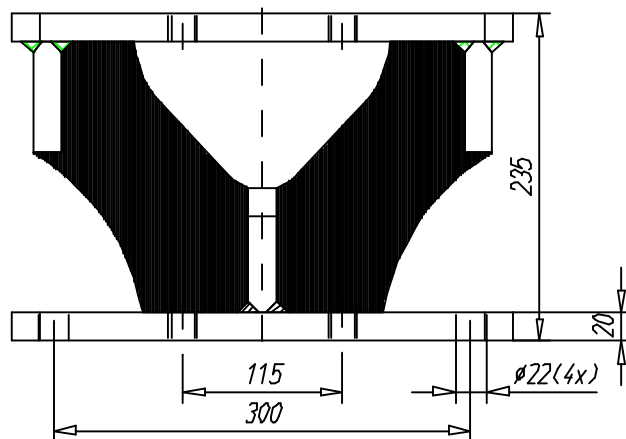
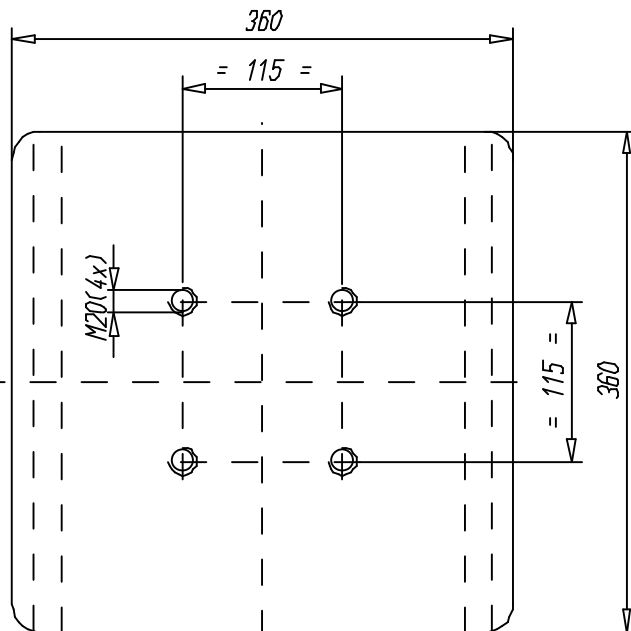

Technical data

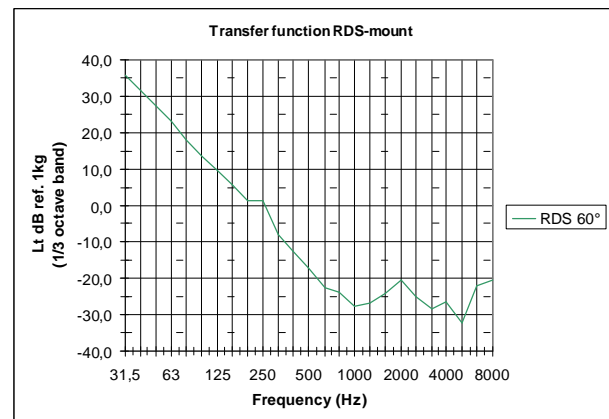
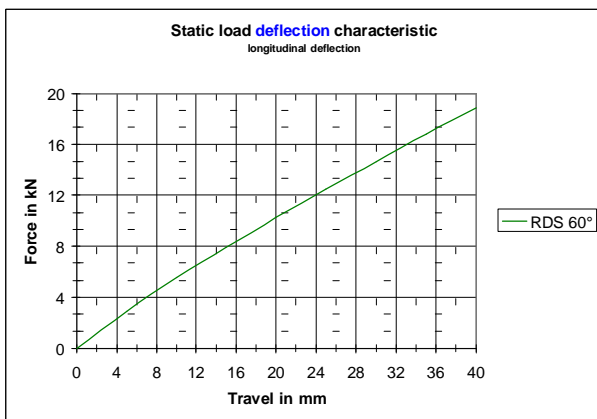
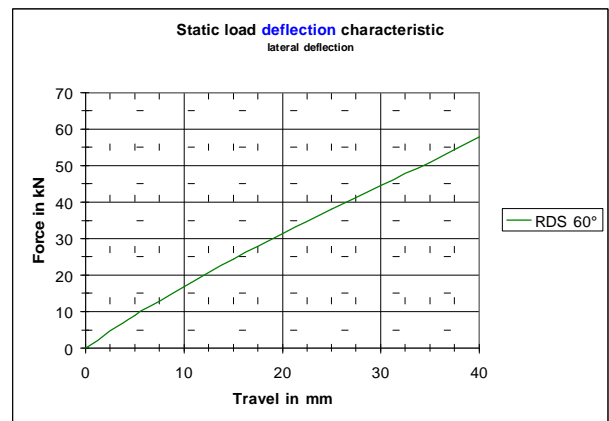
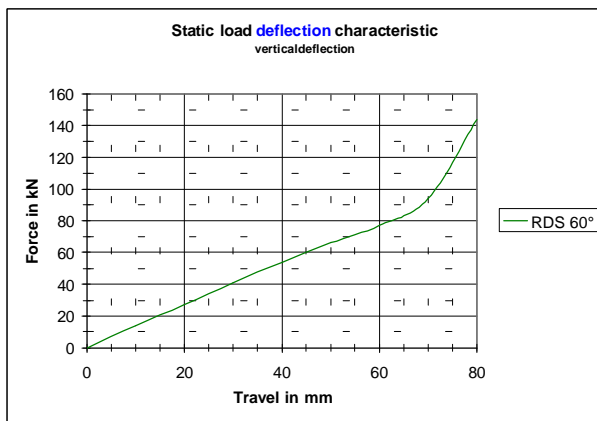
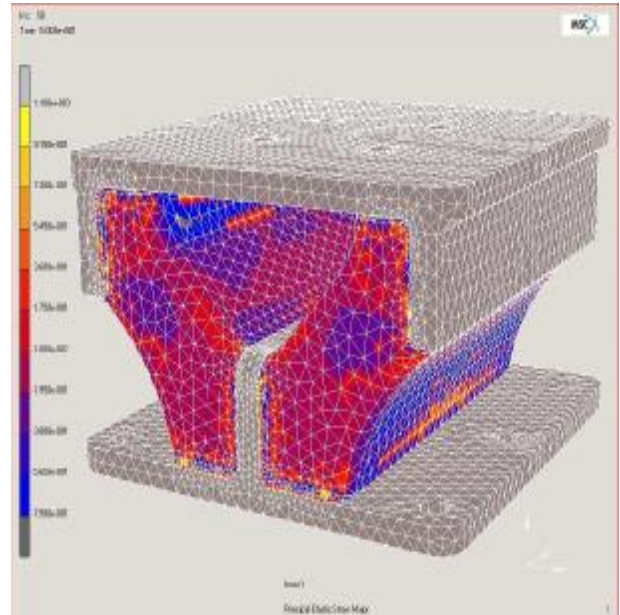
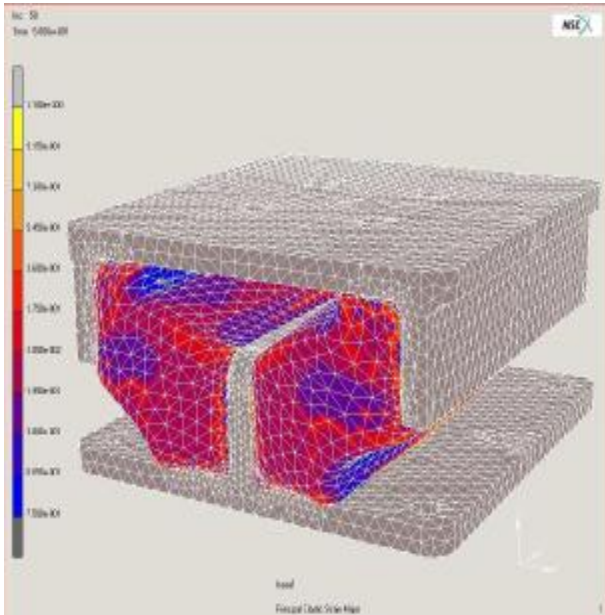

1.2 Shock mounting type RDS-R40

Based on the principals of our RDS-R80 shock mounting, the RDS-R40 adds to the range of high quality shock absorption solutions for marine applications. The nominal load range of the RDS-R40 is placed below the RDS-R80, complementing the range of high quality anti vibration and shock products for a larger equipment range. Working principals are likewise, providing very low transmitted shock under shock loads due to the linear shock load deflection curve. The RDS-R40 works with a linear shock deflection up to 40 mm.

The combination of high shock deflection capabilities and good sound & vibration isolation features, make this mounting the ideal solution for small medium speed diesel engines of generator sets, large pump sets and other rotary equipment. Like all other RDS shock mountings, the RDS-R40 meets the requirements of all international shock specifications like, for example, BV043, BV044, MIL-STD-901, STANAG, MOD BR3021, etc.

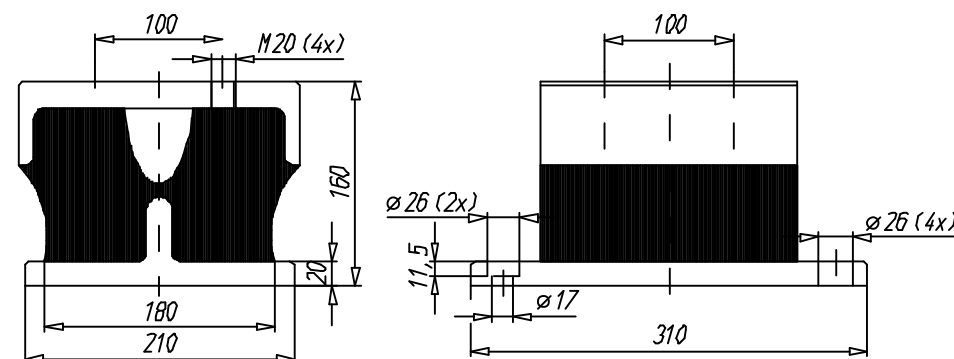
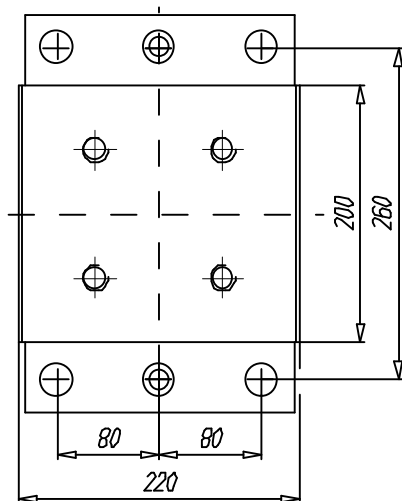
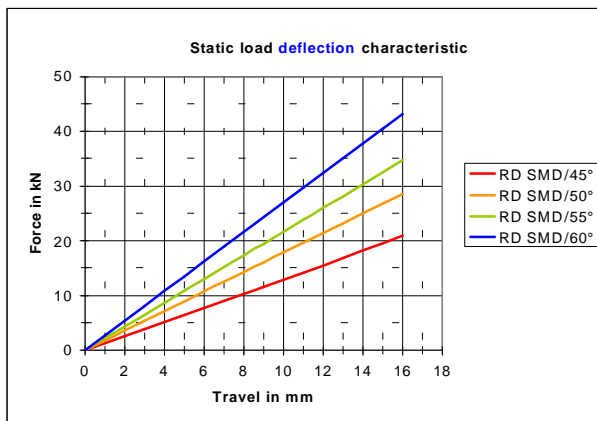

1.3 Shock mounting type RDS-C

General / Applications

In addition to the existing RDS shock mounting range, the new RDS C-165/95, RDS C-165/126 and RDS C-250/154 provide the ideal solution for equipment protection (up to 1500 kg per mounting) like water makers, pump sets, gensets and hydro-packs, whilst also isolating the vibrations of the resiliently mounted equipment.

Features

The unique mounting design characteristics allows absorption of large shock displacements whilst ensuring excellent vibration isolation. The RDS C-mountings have a linear stiffness over a wide range varying from compression to extension, which is necessary to maintain the optimum isolation properties. The maximum deflection of the mounting as a result of shock impact is as large as up to 50 mm in all directions. Due to the conical round shape, the RDS-C mountings have identical stiffness characteristics in longitudinal and transverse direction. A special developed natural

rubber compound for high dynamic loads is used which ensures the best results for long lifetime of the shock mountings. The chosen metals provide a solid vulcanisation base, ensuring high quality within the RDS series.

Quality control

The mountings are individually tested, marked with date of production and identification number before delivery to the customers. The new RDS mountings fulfil the requirements of international shock specifications, such as BV 043, BV 044, MIL 901, STANAG, MOD etc.

Dimensions

The 165/95 S and H have identical dimensions, but different stiffness's and characteristics. Likewise, the 165/126 S and H mountings share identical dimensions, but vary in stiffness and characteristics.

The 250/154S is only available in 'S'-execution.

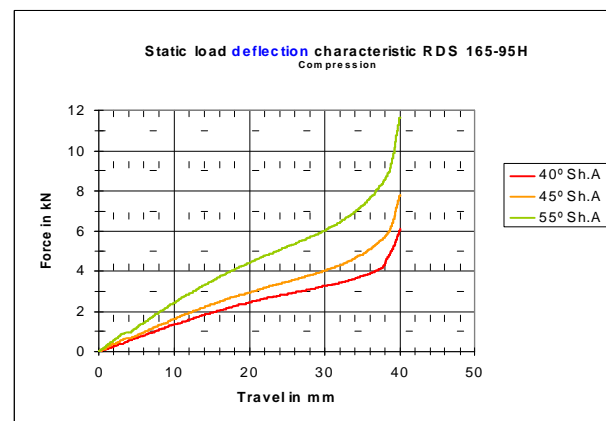
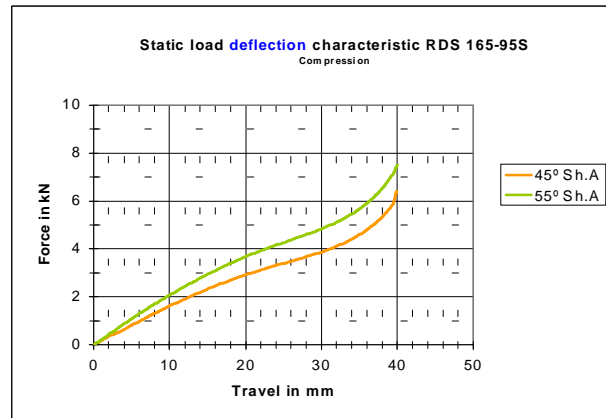
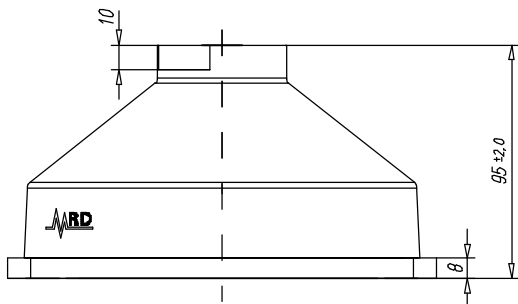
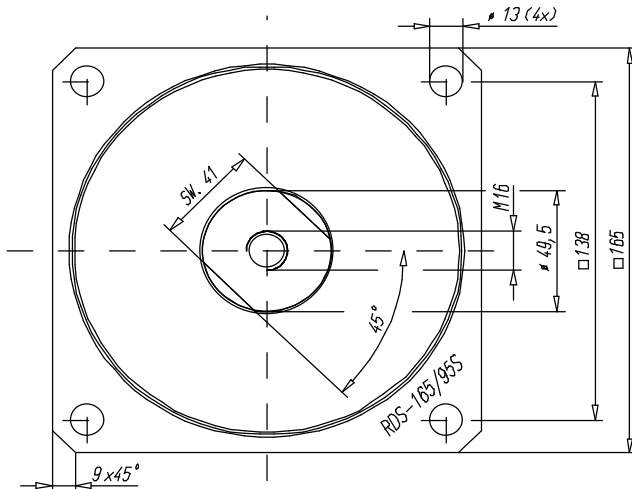

Technical data

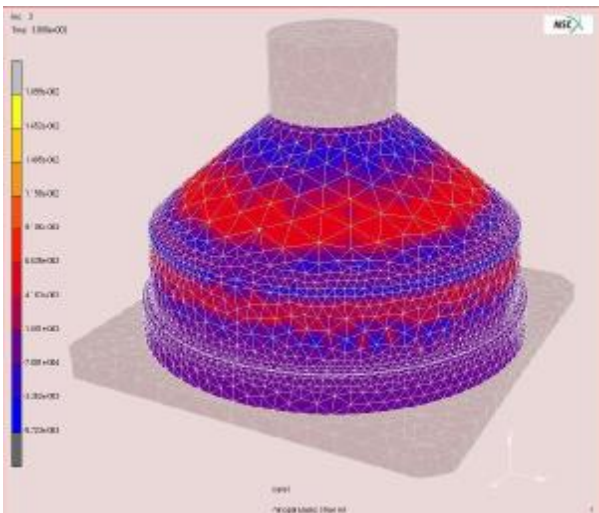
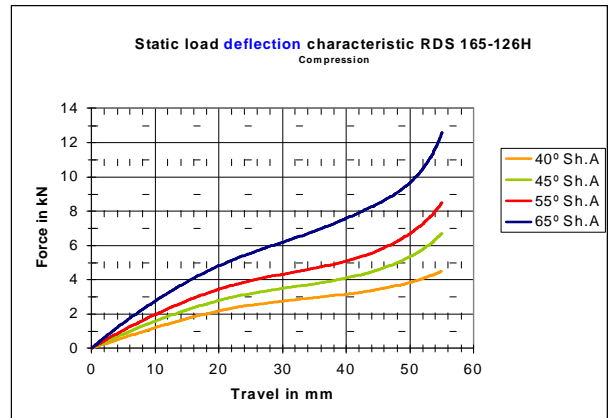
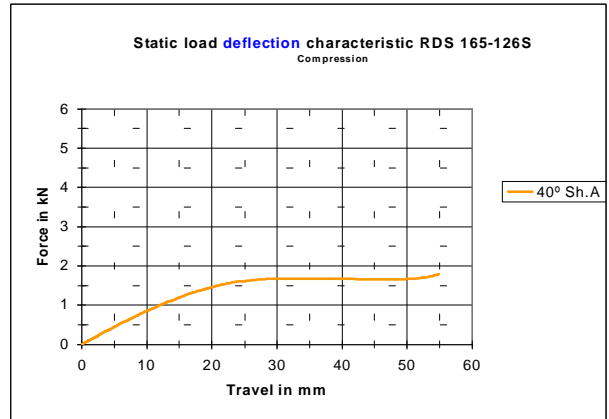
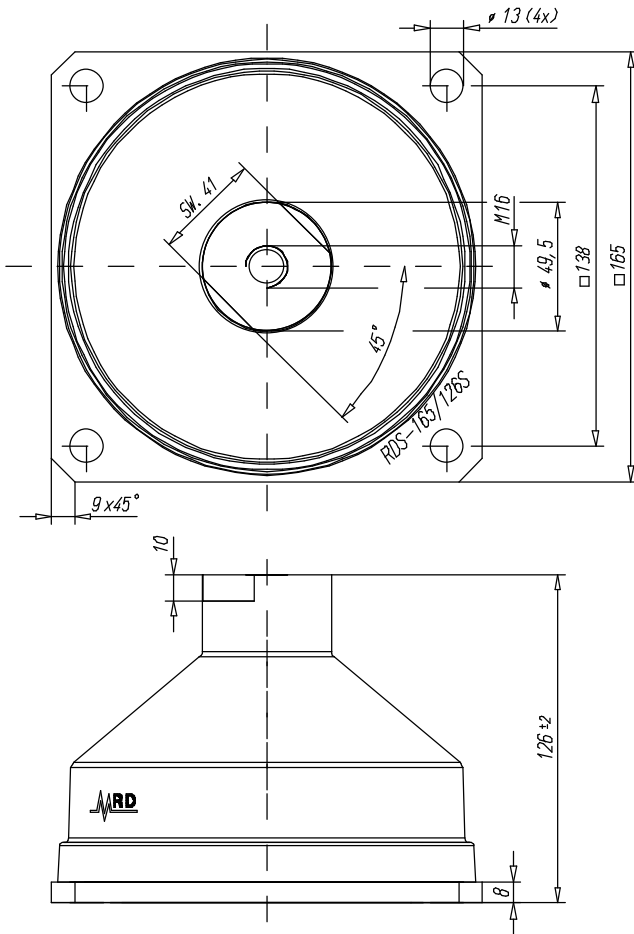

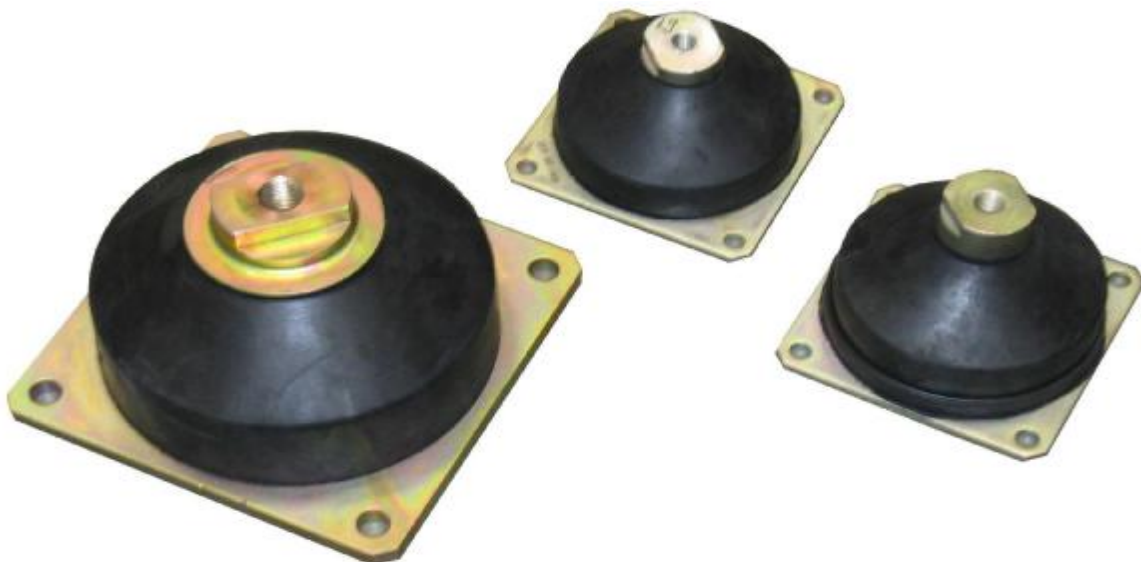
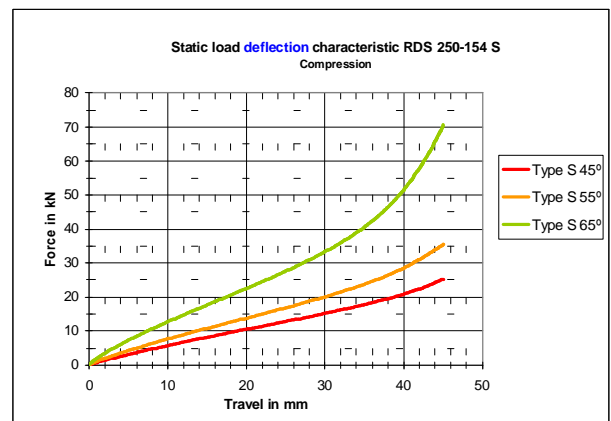
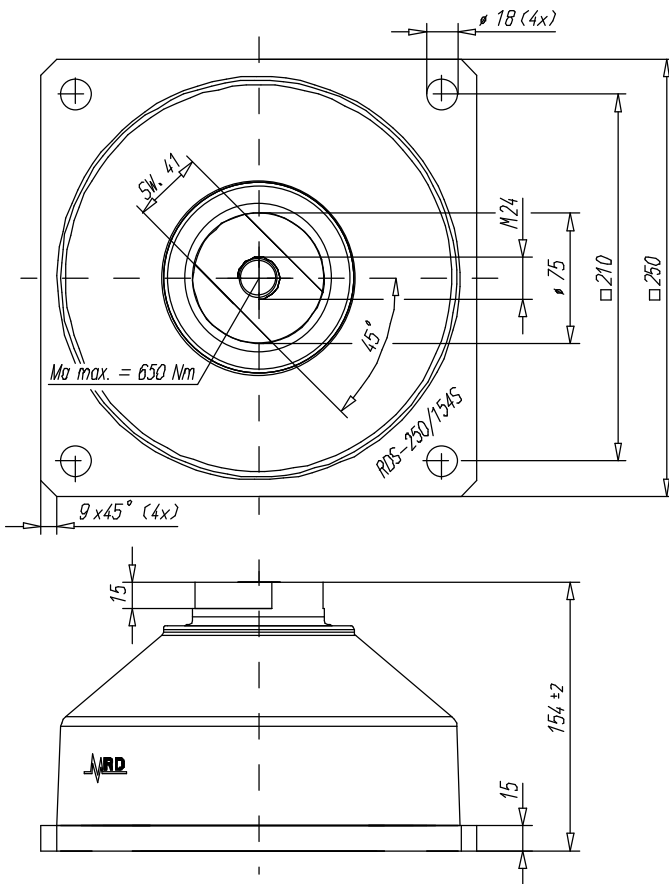

1.4 Shock mounting type RDS-X

The type X leaf spring mounting was first introduced into the Naval Service some years ago by the MOD to isolate equipment from under water shock and to prevent vibration from equipment transferring to a ship's structure and thus water. The present range of this type of mounting is between 10 kg to 450 kg. However, the reduction in the size and mass of ancillary equipment resulted in the addition of mass to accommodate the smallest mounting. There was therefore a requirement for a mounting of similar type but which will support smaller masses. This range of mountings was designed specifically for shipboard applications and is particularly suitable to protect marine equipment from shock due to underwater explosions. When loaded within their recommended range, RDS-X Mountings are capable of attenuating large shock inputs. They are also an effective anti-vibration mounting, having a low natural frequency. The RDS-X Mounting is made from stainless steel strip to BS 1449/302 S 25 hard cold rolled. The leaves are 'U' shaped and riveted or bolted together at the open ends with face plates and spacer plates to form an elliptical shaped assembly. The space between the inner and outer leaves is filled with an epoxy resin

damping compound, and the whole Mounting is coated with neoprene paint. High-impact nylon bushes and washers, with stainless steel backing washers, are provided for improved noise attenuation and load bearing. There are eight sizes for nominal loads ranging from 10 to 450 kg.

Non Magnetic RDS-X Mountings.

RDS-X Mountings can be manufactured for non-magnetic applications. Typical applications are for example: heavy machine tools, air compressors, engine suspensions, machine mountings, laboratory equipment, electric motors, radar communications equipment, electronic control equipment, refrigeration compressors, fuel tanks, blowers and fans, pumps etc. Note: Special care must be taken to ensure that the required clearances are provided around the equipment and the RDS-X Mountings. Precautions must also be taken to ensure that cables, pipes and other connecting services do not interfere with the functioning of the mounting, and that these connections will not themselves be damaged by motion of the equipment under shock.

2 inch

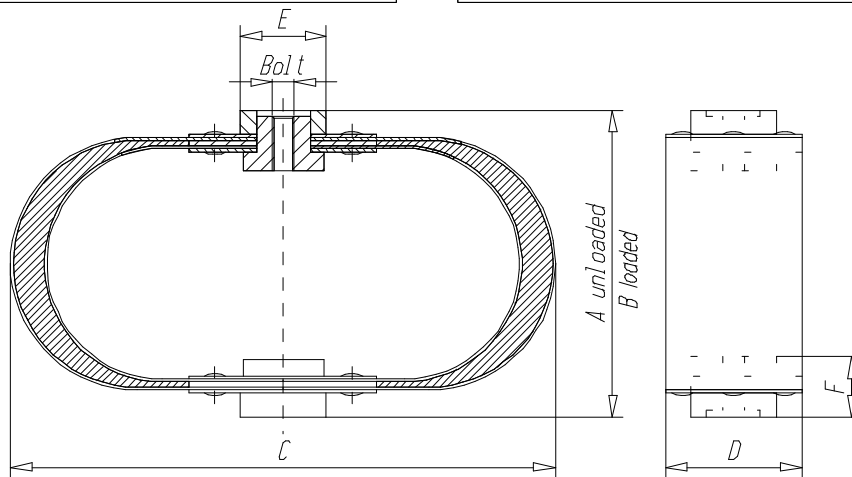
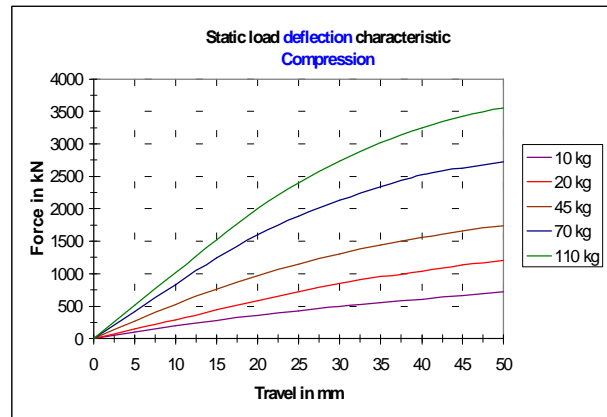
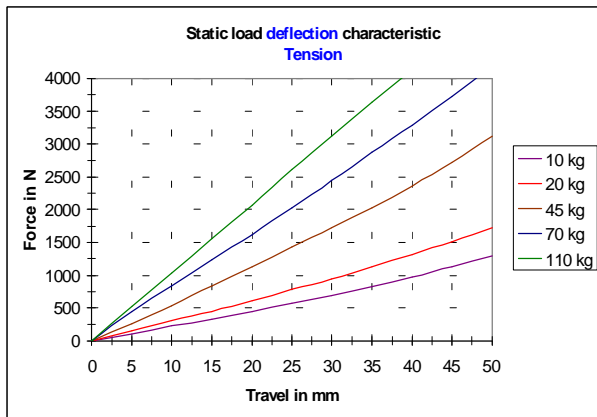

Type	Nato Stock Number (NSN)	Rating (kg)	Supported mass range (kg)	A (mm)	B (mm)	C (mm)	D (mm)	E (mm)	F (mm)	Bolt	Weight (kg)
5717	5340-99-923-5717	10	9 – 18	107	114	203	51	32	23	M8	0.7
5718	5340-99-923-5718	20	18 – 35	106	114	203	51	32	23	M8	0.8
5719	5340-99-923-5719	45	35 – 55	124	133	216	51	32	26	M12	1.0
5720	5340-99-923-5720	70	55 – 90	124	133	216	51	32	26	M12	1.1
5721	5340-99-923-5721	110	90 – 135	122	133	216	51	32	26	M12	1.3

4 inch

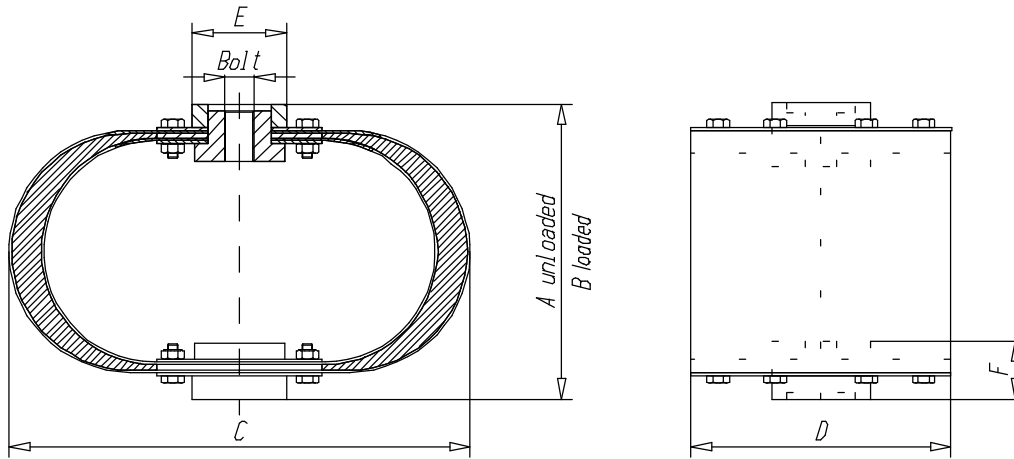

Type	Nato Stock Number (NSN)	Rating (kg)	Supported mass range (kg)	A (mm)	B (mm)	C (mm)	D (mm)	E (mm)	F (mm)	Bolt	Weight (kg)
8429	5340-99-923-8429	180	135 – 250	185	190	297	102	64	43	M20	5.9
8428	5340-99-923-8428	320	250 – 380	186	190	297	102	64	43	M20	6.6
8427	5340-99-923-8427	450	380 – 550	184	190	297	102	64	43	M20	7.3

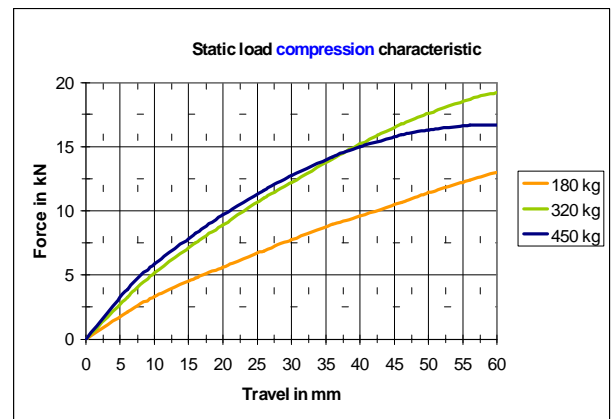
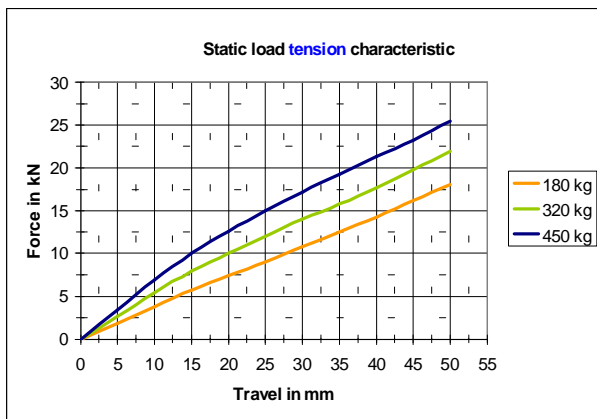

Technical details

Type		5717	5718	5719	5720	5721	8429	8428	8427
Nominal load		10	20	45	70	110	180	320	450
Transmitted Acceleration									
V = Vertical	m/s ²	150	150	150	150	150	150	150	150
H _s = Horizontal Across	m/s ²	150	150	150	150	150	150	150	150
H _r = Vertical Across	m/s ²	50	50	50	50	50	50	50	50
Natural frequency and shock natural frequency (Acceleration&Deceleration)									
V = Vertical	Hz	6.50-8.50	6.50-8.50	7.50-8.50	6.50-8.50	7.00-8.50	9.50-13.00	8.00-9.50	7.50-9.50
H _a = Horizontal Across	Hz	4.50-6.25	4.50-6.25	5.00-6.25	4.50-6.25	5.00-6.25	4.75-6.50	5.25-6.00	4.75-6.00
H _r = Vertical Across	Hz	3.50-5.00	3.50-5.00	4.25-5.00	4.00-5.00	4.25-5.00	4.00-5.00	4.25-5.00	4.00-5.00
Max. shock deflection									
V = Vertical	mm	60	60	60	60	60	60	60	60
H _a = Horizontal Across	mm	40	40	40	40	40	40	40	40
H _r = Vertical Across	mm	40	40	40	40	40	40	40	40
Static stiffness									
V = Vertical	kN/m	13	26	44	70	120	350	500	875
H _a = Horizontal Across	kN/m	17	35	58	91	149	665	788	1400
H _r = Vertical Across	kN/m	7	14	24	39	61	175	219	385
Dynamic stiffness									
H _r = Vertical Across	kN/m	30	58	122	150	261	891	960	1221
H _s = Horizontal Across	kN/m	30	58	122	150	261	891	960	1221
H _r = Vertical Across	kN/m	9	14	39	57	96	158	271	347
Dynamic factors									
H _r = Vertical Across		2.3	2.2	2.8	2.1	2.2	2.5	1.9	1.4
H _s = Horizontal Across		1.8	1.7	2.1	1.6	1.8	1.3	1.2	0.9
H _r = Vertical Across		1.3	1.0	1.6	1.5	1.6	0.9	1.2	0.9
Stiffness ratio	H								
R _a = Horizontal Across		1.3	1.3	1.3	1.3	1.90	1.6	1.6	1.6
R _r = Horizontal Roll		0.55	0.55	0.55	0.55	0.55	0.50	0.45	0.45
Support stiffness	kN/m	200	450	900	1300	2000	3500	6000	8500
Support strength	N	150	300	675	1050	1650	2700	4800	6750



1.5 Shock mounting type RDS-XM

The RDS-XM mounting is an all-metal version of the RDS-X mounting, which will maintain its properties over a wider temperature range than the RDS-X mounting. RDS-XM mountings are essentially similar to the RDS-X mountings, utilising the same leaf spring assembly, except that the epoxy resin damping compound has been replaced by stainless steel mesh inserts.

Whereas the inclusion of the epoxy resin damping compound rendered the RDS-X mounting temperature sensitive (with optimum isolation efficiency at +15° to +20° C) the mesh inserts will operate over a range of -150° to +400° C with little change to the damping properties. In addition the RDS-XM has a reduction in natural frequency of the system.

The RDS-X and RDS-XM are the most space efficient of all shock mountings, having originally been developed for submarines. The

elliptical leaf spring assembly enables the RDS-X and RDS-XM to have at least +/- 60mm of displacement under vertical shock conditions, within their low overall height. In addition, they have +/- 40mm of displacement to provide friction damping. Some mountings, other than leaf springs, are often employed at 45° to the vertical in an effort to equalise the stiffness in all directions. This increases the overall space envelope.

The RDS-X mounting is part of the British 'Admiralty' range of standardised mountings all NATO codified and made to Naval Engineering Standards. The RDS-XM utilises the same leaf springs and is intended to be directly interchangeable with the RDS-X mounting for extreme environmental conditions. The table below gives dimensional details of the range of RDS-XM mountings.

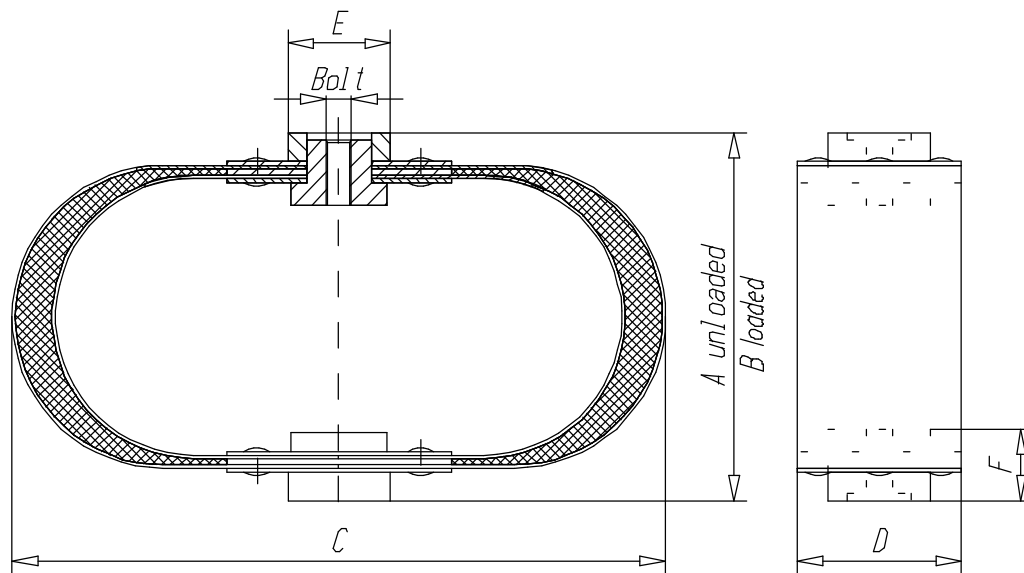

Type	Nato Stock Number (NSN)	Rating (kg)	Supported mass range (kg)	A (mm)	B (mm)	C (mm)	D (mm)	E (mm)	F (mm)	Bolt	Weight (kg)
	Not allocated	10	9 – 18	107	114	203	51	32	23	M8	0.7
	Not allocated	20	18 – 35	106	114	203	51	32	23	M8	0.8
	Not allocated	45	35 – 55	124	133	216	51	32	26	M12	1.0
	Not allocated	70	55 – 90	124	133	216	51	32	26	M12	1.1
	Not allocated	110	90 – 135	122	133	297	51	32	26	M12	1.3
	Not allocated	180	135 – 250	185	190	297	102	64	43	M20	5.9
	Not allocated	320	250 – 380	186	190	297	102	64	43	M20	6.6
	Not allocated	450	380 – 550	184	190	297	102	64	43	M20	7.3

1.6 Shock mountings type RDS-Y

The mounting is a modified version of the type RDS-X mounting, developed by the Ministry of Defense to provide improved noise attenuation at higher frequencies. The essential improvement in noise attenuation is provided by precisely compounded rubber mouldings, forming the accelerator and decelerator units. These mouldings act as a high frequency isolator providing increased 'stealth' performance over the RDS-X mounting.

The RDS-Y mounting as a development of the RDS-X mounting gives similar shock but better vibration protection, compared with other mountings approved by the MOD for Naval use. Applications are similar to the RDS-X mounting with the same restrictions on use applying to use in the ship's masthead region or after 1/8th of the ship's length. Special care must be taken to ensure that the required clearances are provided around the equipment. This is

necessary to reduce the risk of damage to motion of the mountings during shock. RDS-Y mountings have been used to reduce the vibration and noise transmitted through the ship's hull by such equipment as refrigeration compressors, air compressors, pumps, blowers and fans, engines etc.

The table below gives dimensional details of the range of RDS-Y mountings, which are based on the RDS-X mountings. There are eight load sizes with nominal loads ranging from 10 to 450 kg. These sizes fall into three groups dimensionally i.e. 10 20; 45 70 110; 180 320 450. Groups one and two are 51 mm wide with group three 102 mm wide.

The RDS-Y mounting can be delivered with two types fixing kits, consisting of bolts, washers and a distance piece.

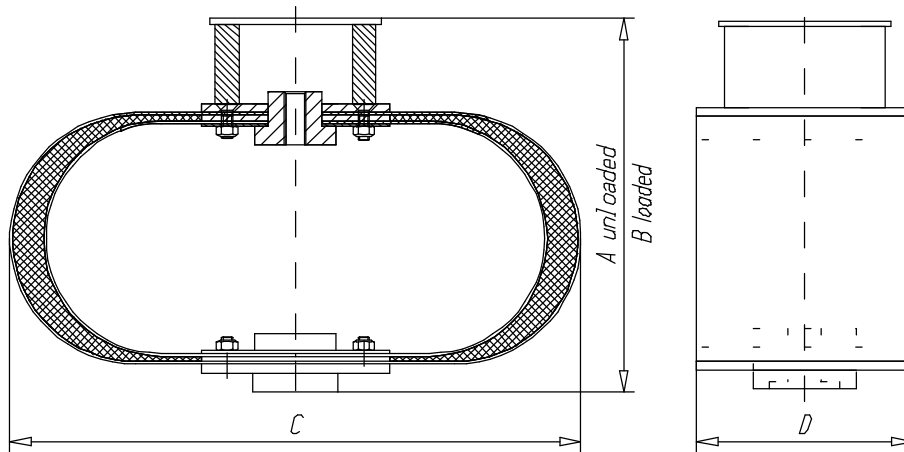

Type	Nato Stock Number (NSN)	Rating (kg)	Supported mass range (kg)	A (mm)	B (mm)	C (mm)	D (mm)	Top Bolt	Bottom Bolt
9769	5340-99-778-9769	10	9 – 18	124	134	203	51	M6	M8
9770	5340-99-778-9770	20	18 – 25	124	134	203	51	M6	M8
9771	5340-99-778-9771	45	35 – 55	151	166	216	51	M10	M12
9772	5430-99-778-9772	70	55 – 75	151	166	216	51	M10	M12
9773	5430-99-778-9773	110	90 – 125	151	166	297	51	M10	M12
9774	5430-99-778-9774	180	135 – 250	219	228	297	102	M16	M20
9775	5430-99-778-9775	320	250 – 385	214	228	297	102	M16	M20
9776	5430-99-778-9776	450	380 – 500	214	228	297	102	M16	M20

1.7 Shock mountings type RDS-J

Suitable for shock mounting applications, where alignment with either equipment or ships structure need not be maintained after shock, and where vibration protection or isolation is not a requirement.

The mounted item may be displaced from its original position by plastic yielding of the mounts as a result of shock. But it may be possible to regain shock protection, as an emergency measure, by forcing the mounts back into their original shape.

The J Mount is commonly employed for the shock protection of

robust electrical distribution equipment, including switch and control gear.

The J Mount is a curved metal strap designed to yield at a predetermined load in any direction under shock.

The mount is self-contained, needing no separate or additional associated devices (i.e. Decelerators). It is cost effective and requires little maintenance because its zinc plated surface protects it against corrosion. The J mount is an effective shock mount, with only minor shortcomings in deflection capabilities.

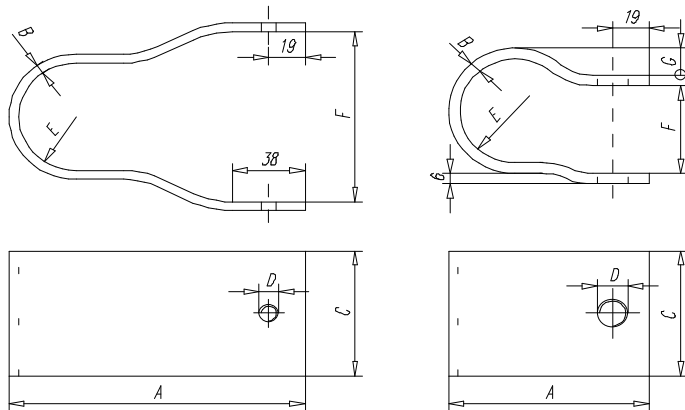

J Mount 'A' and J Deck Mounting

J Bulkhead Mounting

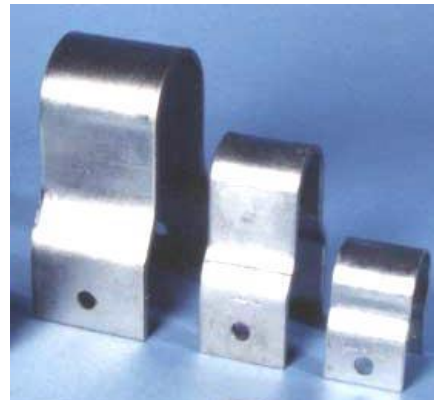

J mounts 'A' Range (metric)

NATO Stock Number	Mount Size No.	Mass Range (kg)	A (mm)	B (mm)	C (mm)	D (mm)	E (mm)	F (mm)
5340-99-539-6795	03A	2 - 5	151	2	55	M8	30	95
5340-99-539-6794	02A	5 - 10	152	3	55	M8	30	95
5340-99-539-6793	01A	10 - 20	153	4	55	M10	30	95
5340-99-533-2588	1A	20 - 35	154	5	70	M10	30	95
5340-99-533-2589	2A	35 - 45	154	5	90	M10	30	95
5340-99-533-2590	3A	45 - 60	155	6	85	M12	30	95
5340-99-533-2591	4A	60 - 80	155	6	105	M12	30	95
5340-99-533-2592	5A	80 - 115	157	8	95	M16	30	95
5340-99-533-2593	6A	115 - 180	159	10	85	M20	30	95

J Bulkhead mounts (metric)

NATO Stock Number	Mount Size No.	Mass Range (kg)	A (mm)	B (mm)	C (mm)	D (mm)	E (mm)	F (mm)	G (mm)	H (mm)
5340-99-533-2576	1	2 - 5	69	2	55	M10	19	38	6	25
5340-99-533-2577	2	5 - 10	69	3	55	M10	19	38	6	25
5340-99-533-2578	3	10 - 20	76	4	55	M12	21	40	8	25
5340-99-533-2579	4	20 - 35	105	6	70	M16	29	49	15	32
5340-99-533-2580	5	35 - 70	125	8	90	M20	35	67	9	44
5340-99-533-2581	6	70 - 135	159	12	85	M24	44	83	11	57

J Deck mounts (Original Range - metric)

NATO Stock Number	Mount Size No.	Mass Range (kg)	A (mm)	B (mm)	C (mm)	D (mm)	E (mm)	F (mm)
5340-99-533-2582	1	20 - 35	116	5	45	M10	19	64
5340-99-533-2583	2	35 - 45	116	5	55	M10	19	64
5340-99-533-2584	3	45 - 60	117	6	55	M12	19	64
5340-99-533-2585	4	60 - 80	117	6	70	M12	19	64
5340-99-533-2586	5	80 - 115	119	8	65	M16	19	64
5340-99-533-2587	6	115 - 180	121	10	65	M20	19	64

1.8 Maintenance of the RDS-Mountings

- The life expectancy of the rubber elements will be approximately 20 years in ideal circumstances. Unfortunately ideal circumstances are not feasible, therefore the (working) life expectancy will be approx. 10 years. The life expectancy of the rubber elements is dependent on the environmental circumstances (weather influences, contaminants, etc).
 - A visual inspection of the RDS-Mountings should be carried out six months after installation and should be repeated every year. For better recognition of damages you can use a blunt pin. The use of a screwdriver is not advisable, because of the damage it can cause to the conical mountings.
 - The use of a natural rubber (NR) compound for the rubber elements means that they are not oil resistant. The occasional occurrence of oil-leaks does not effect the working of the conical mountings, because the oil will only damage the surface of the rubber elements. In case of oil contamination the rubber elements will show some signs of swelling.
 - When cleaning the engine or the engine room with a solvent cleansing agent, it is advisable to cover up the RDS-Mountings. If the cleansing agent still contaminates the rubber elements, they should be cleaned als follows.
- Storage, cleaning and maintenance of the rubber elements should be done in accordance with DIN 7716. The cleaning of the RDS-Mountings should be done with a normal (household) cleansing agent. It is also advisable to use a glycerine-alcohol mixture (1:10). Do not use a solvent cleansing agent.
 - In cases where it is necessary to replace the RDS-Mounting, we advise return of the RDS-Mounting to Rubber Design BV.
 - If required, the RDS-mounting can be painted by the customer, Be aware that only the top- and base plate of the RDS-Mounting can be painted. Do not use paint on the rubber element as the rubber element might be contaminated and therefore be damaged.
 - All deliveries are stored for over 20 years in a database including all relevant data and characteristics.

