

Table of content

General

1.1	General	Page 2
1.2	Flanged compensators A60 class	Page 3
1.3	Clamped compensators A0 and A60 class	Page 4

Certificates

2.1	Certificate of fire approval	Page 5
2.2	EC type examination (module B) certificate	Page 6

Built-in instructions

3.1	Clamped texture compensators	Page 7
3.2	Flanged texture compensators	Page 8

1.1 General

General

Our FiProTex® single pipe penetration is a fireproof sealing system. Specially developed by our design team to allow (exhaust) pipe-constructions to pass decks without transmitting vibration, noise or heat to the surrounding ship-structure.

In this unique product only the best quality fabrics and insulation materials are combined. This guarantees maximum safety and performance. The FiProTex® single pipe penetration seals, depending on the selected configuration, are suitable for A0, A15, A30 and A60 Decks.

The FiProTex® single pipe penetration seals provide:

- Compensation of thermal and or mechanical movement in axial, lateral or angular direction.
- Isolation of vibration and heat and pipe work borne sound transmission.
- Low reaction force due to movements
- Separation of compartments
- Compensation of pipework misalignment
- LroS type approval

Construction

The design consists of a cuff, which on one side is mounted to the deck, either with a flange or a sleeve-on construction. The counter side is mounted in a similar way to the pipe construction that passes the deck. Depending on the construction method preferred, the FiProTex® single pipe penetration seals can be supplied in both a split and a non-split version.

Features

The FiProTex® single pipe penetration seals are manufactured of a special glass fibre cloth with aluminium coating. Depending on the insulation arrangement requirement, a layer of mineral wool will be inserted.

Certification.

The products detailed in this brochure will be accepted for compliance with the applicable Lloyd's Register Rules and Regulations and with the international Convention for the Safety of life at Sea (SOLAS), 1974, as amended, for use on ships and offshore installations classed with Lloyd's Register and for use on ships and offshore installations when authorised by contracting governments to issue the relevant certificates, licences, permits, etc.



1.2 Dimensions flanged compensators

Type A60

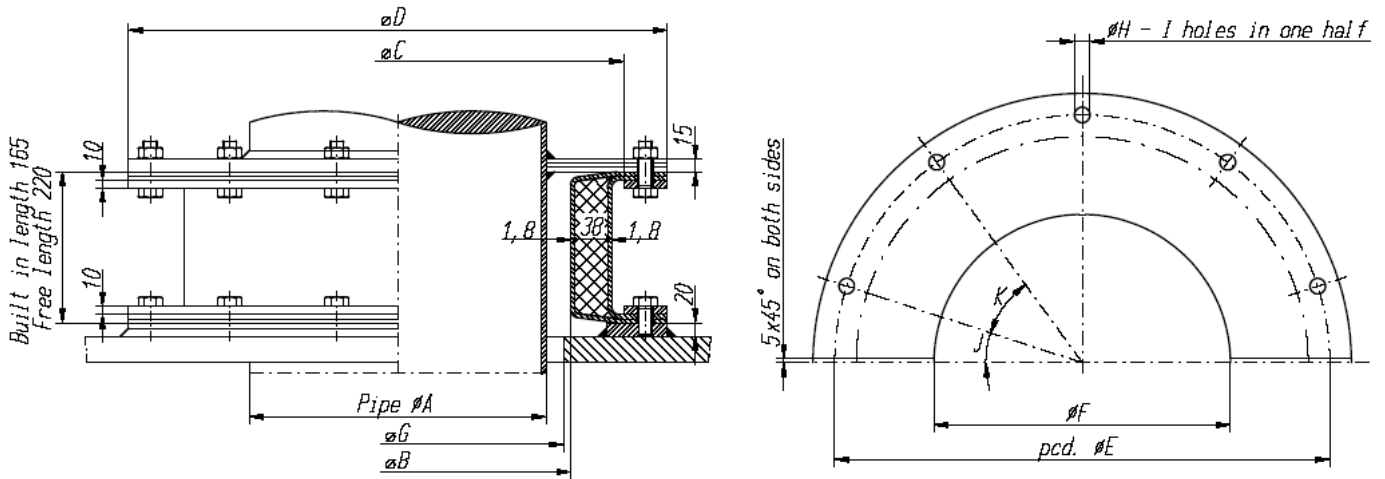

N.B. (A)	B	C	D	E	F	G	H	I	J	K
60.3	169	259	359	309	61	130	∅14	3 x	30°	2 x 60°
76.1	169	259	359	309	77	130	∅14	3 x	30°	2 x 60°
88.9	169	259	359	309	90	130	∅14	3 x	30°	2 x 60°
114.3	195	285	385	335	116	155	∅14	3 x	30°	2 x 60°
139.7	220	310	410	360	141	180	∅14	4 x	22.5°	3 x 45°
168.3	248	338	438	388	170	210	∅14	4 x	22.5°	3 x 45°
193.7	275	365	465	415	195	240	∅14	4 x	22.5°	3 x 45°
219.1	300	390	490	440	220	265	∅14	4 x	22.5°	3 x 45°
273.0	353	443	543	493	274	315	∅14	4 x	22.5°	3 x 45°
323.9	403	475	575	525	325	370	∅14	4 x	22.5°	3 x 45°
355.6	435	520	620	570	357	400	∅14	5 x	18°	4 x 36°
406.4	486	576	676	626	408	450	∅14	5 x	18°	4 x 36°
457.2	537	620	720	670	459	510	∅14	5 x	18°	4 x 36°
508.0	588	678	778	728	510	560	∅18	6 x	15°	5 x 30°
559.0	630	720	820	770	560	600	∅18	6 x	15°	5 x 30°
608.0	680	750	850	800	610	650	∅18	6 x	15°	5 x 30°
711.0	780	850	950	900	713	750	∅18	8 x	11.25°	7 x 22.5°
813.0	893	980	1080	1030	815	860	∅18	8 x	11.25°	7 x 22.5°
914.0	990	1080	1180	1130	916	960	∅18	8 x	11.25°	7 x 22.5°
1016.0	1090	1180	1280	1230	1018	1070	∅18	8 x	11.25°	7 x 22.5°
1120.0	1200	1290	1390	1340	1122	1170	∅18	10 x	9°	9 x 18°
1220.0	1300	1390	1490	1440	1222	1270	∅18	10 x	9°	9 x 18°
1320.0	1400	1490	1590	1540	1322	1370	∅18	10 x	9°	9 x 18°
1420.0	1500	1590	1690	1640	1422	1470	∅18	10 x	9°	9 x 18°
1520.0	1600	1690	1790	1740	1522	1570	∅18	10 x	9°	9 x 18°
1620.0	1700	1790	1890	1840	1622	1670	∅18	15 x	6°	14 x 12°
1720.0	1800	1890	1990	1940	1722	1770	∅18	15 x	6°	14 x 12°
1820.0	1900	1990	2090	2040	1822	1870	∅18	15 x	6°	14 x 12°
1920.0	2000	2090	2190	2140	1922	1970	∅18	15 x	6°	14 x 12°
2020.0	2100	2190	2290	2240	2022	2070	∅18	20 x	4.5°	19 x 9°
2120.0	2200	2290	2390	2340	2122	2170	∅18	20 x	4.5°	19 x 9°
2220.0	2300	2390	2490	2440	2222	2270	∅18	20 x	4.5°	19 x 9°
2320.0	2400	2490	2590	2540	2322	2370	∅18	20 x	4.5°	19 x 9°

Allowable single movements: +/- 55 mm axial. +/- 15 mm lateral. Combined movements at reduced rates. Other dimensions on request.

1.3 Dimensions clamped compensators

Type A60/A0

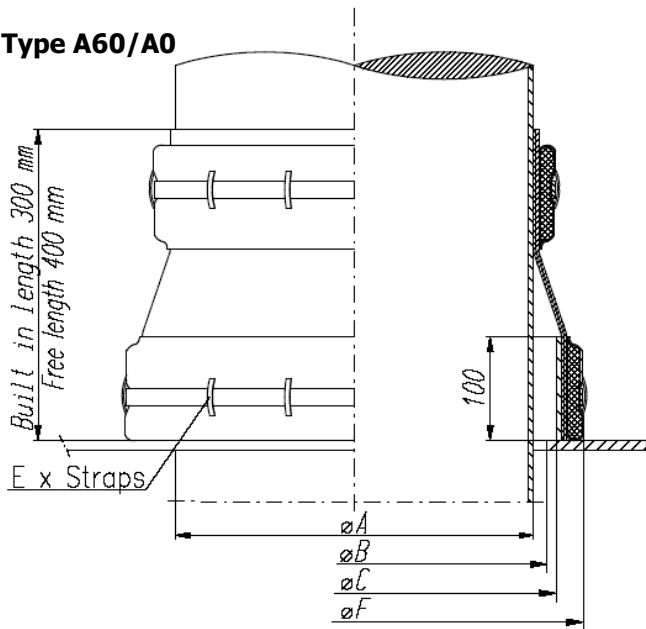

A0 Class

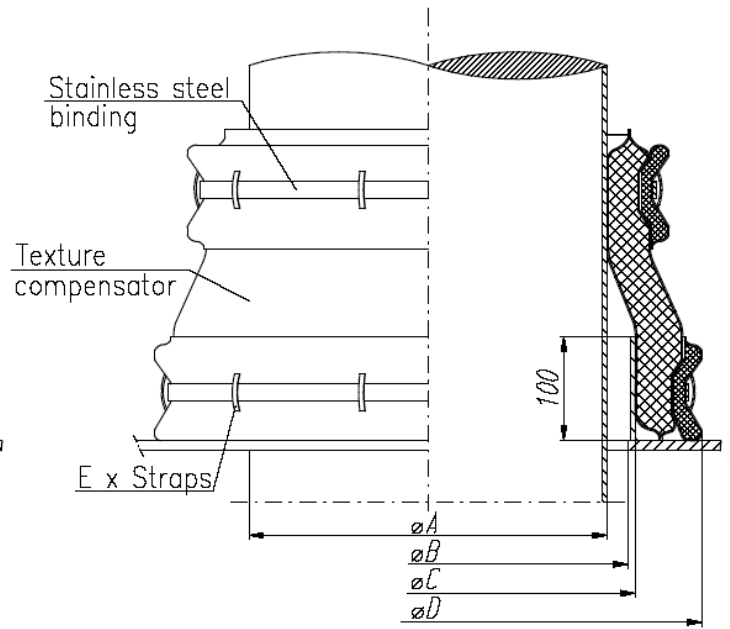

A60 Class

N.B. (A)	B	C	D	E	F
139.7	180	199	300	2	240
168.3	210	231	330	2	270
193.7	235	254	355	2	295
219.1	260	282	380	2	320
273.0	315	336	435	2	375
323.9	365	386	485	2	425
355.6	395	418	520	2	460
406.4	450	469	570	3	510
457.2	500	521	620	3	560
508.0	550	571	670	3	610
559.0	590	610	710	3	650
608.0	650	671	770	4	710
711.0	750	774	875	4	815
813.0	850	876	975	5	915
914.0	955	977	1080	5	1020
1016.0	1055	1079	1180	6	1120
1120.0	1160	1183	1285	7	1225
1220.0	1260	1283	1385	7	1325
1320.0	1360	1383	1485	8	1425
1420.0	1460	1483	1585	8	1525
1520.0	1560	1583	1685	9	1625
1620.0	1660	1683	1785	9	1725
1720.0	1760	1783	1885	10	1825
1820.0	1860	1883	1985	10	1925
1920.0	1960	1983	2085	12	2025
2020.0	2060	2083	2185	12	2125
2120.0	2160	2183	2285	12	2225

Allowable single movements: +/- 55 mm axial. +/- 15 mm lateral. Combined movements at reduced rates. Other dimensions on request.

2.1 Certificate of fire approval



CERTIFICATE OF FIRE APPROVAL

This is to certify that

The product detailed below will be accepted for compliance with the applicable Lloyd's Register Rules and Regulations and with the International Convention for the Safety of Life at Sea, (SOLAS), 1974, as amended, for use on ships and offshore installations classed with Lloyd's Register, and for use on ships and offshore installations when authorised by contracting governments to issue the relevant certificates, licences, permits etc.

Manufacturer	Rubber Design B.V.
Address	Industrieweg 21 2995 BE Herjansdam The Netherlands,
Type	PIPE PENETRATION (STANDARD FIRE TEST)
Description	Single Pipe Penetration – Type: "Fiprotex"
Specified Standard	IMO Fire Test Procedures Code, Annex 1, Part 3

The attached Design Appraisal Document forms part of this certificate.

This certificate remains valid unless cancelled or revoked, provided the conditions in the attached Design Appraisal Document are complied with and the equipment remains satisfactory in service.

Date of issue	10 August 2005	Expiry date	9 August 2010
---------------	----------------	-------------	---------------

Certificate No.	SAS F050277
-----------------	-------------

Signed	
--------	---

Sheet No	1 of 2
----------	--------

Name	B. McDonald
------	-------------



Surveyor to Lloyd's Register EMEA
 A Member of the Lloyd's Register Group

Note:

This certificate is not valid for equipment, the design or manufacture of which has been varied or modified from the specimen tested. The manufacturer should notify Lloyd's Register of any modification or changes to the equipment in order to obtain a valid Certificate.

"Lloyd's Register, its affiliates and subsidiaries and their respective officers, employees or agents are, individually and collectively, referred to in this clause as the 'Lloyd's Register Group'. The Lloyd's Register Group assumes no responsibility and shall not be liable to any person for any loss, damage or expense caused by reliance on the information or advice in this document or howsoever provided, unless that person has signed a contract with the relevant Lloyd's Register Group entity for the provision of this information or advice and in that case any responsibility or liability is exclusively on the terms and conditions set out in that contract."

2.2 EC type examination (module B) certificate

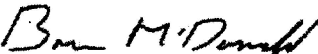
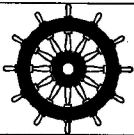
	USCG-EU MRA	 <small>Maritime and Coastguard Agency An Executive Agency of the Department for Transport</small>	
EC TYPE EXAMINATION (MODULE B) CERTIFICATE			
This is to certify that :			
LLOYD'S REGISTER VERIFICATION LIMITED (LRV), specified as a "notified body" under the terms of The Merchant Shipping (Marine Equipment) Regulations S.I. 1999 No. 1957, did undertake the relevant type approval procedures for the equipment identified below which was found to be in compliance with the essential Fire protection requirements of Marine Equipment Directive (MED) 96/98/EC as modified by Commission Directives 98/85/EC, 2001/53/EC, 2002/75/EC and 2002/84/EC subject to any conditions in the Design Appraisal Document attached hereto.			
Manufacturer	Rubber Design B.V.		
Address	Industrieweg 21 2995 BE Herjansdam The Netherlands,		
Annex A1 Item USCG Category Number	A.1/3.26 - PENETRATIONS THROUGH 'A' CLASS DIVISIONS (b) Pipe, duct, trunk etc penetrations 164.138 - PENETRATIONS THROUGH 'A' CLASS DIVISIONS BY ELECTRIC CABLES, PIPES, TRUNKS, DUCTS ETC.		
Product Type	PIPE PENETRATION (STANDARD FIRE TEST)		
Product Description	Single Pipe Penetration - Type: "Fiprotex"		
Specified Standard	IMO Fire Test Procedures Code, Annex 1, Part 3		
The attached Design Appraisal Document (schedule) forms part of this certificate. This certificate remains valid unless cancelled or revoked, provided the conditions in the attached schedule are complied with and the equipment remains satisfactory in service.			
Date of issue	10 August 2005	Expiry date	9 August 2010
Certificate No.	MED 0550223	Signed	
Sheet No	1 of 2	Name	B. McDonald For and on behalf of Lloyd's Register Verification LRV EC Distinguishing No. 0038
Note:			
This certificate is not valid for equipment; the design or manufacture of which has been varied or modified from the specimen tested. The manufacturer should notify the notified body named on this certificate of any modification or changes to the equipment in order to obtain a valid Certificate.			
 0038/yy	Subject to compliance with the conditions in the attached Design Appraisal Document (schedule), which forms part of this certificate, and those of Articles 10.1(f) and 11 of the Directive, the Manufacturer is allowed to affix the "Mark of Conformity" to the Product described herein.		
yy = Last two digits of year mark affixed.			
This product has been assigned a U.S. Coast Guard Module B number:			
USCG Module B number: 164.138/EC0038/MED 0550223			
USCG-EU MRA			
to note type approval to Module B only as it pertains to obtaining U. S. Coast Guard approval as allowed by the "Agreement between the European Community and the United States of America on Mutual Recognition of Certificates of Conformity for Marine Equipment" signed February 27th, 2004.			
This certificate is issued under the authority of the MCA.			
Lloyd's Register Verification is the business name of Lloyd's Register Verification Limited, a member of the Lloyd's Register Group. Registration number 4929226. Registered office 71 Fenchurch Street, London EC3M 4BS, England.			
<small>"Lloyd's Register, its affiliates and subsidiaries and their respective officers, employees or agents are, individually and collectively, referred to in this clause as the 'Lloyd's Register Group'. The Lloyd's Register Group assumes no responsibility and shall not be liable to any person for any loss, damage or expense caused by reliance on the information or advice in this document or howsoever provided, unless that person has signed a contract with the relevant Lloyd's Register Group entity for the provision of this information or advice and in that case any responsibility or liability is exclusively on the terms and conditions set out in that contract."</small>			

3.1 Assembly instructions clamped fabric compensators

To install a clamped fabric compensator in a proper way, you have to follow the instructions below.

1. Weld the clamp ring to the deck. Take care of the right position.
2. For the splitted version (A60 only): Fold the fabric compensator around the pipe and the clamp ring. Glue the contact surfaces with the delivered silicone paste and fix them together. Don't touch the glue; use a spatula to spread out the glue. Install the supplied stainless steel (AISI 201) binding around the compensator and the clamp ring, through the straps and tighten the binding with the supplied tensioning tool. Wait with the other binding, these one will be mounted in step 4. Carefully follow the instructions supplied with the tool. Wait for twenty-four hours before proceeding to the next step.

For the non-splitted version: Situate the compensator around the pipe and install the stainless steel binding in the same way as mentioned above.

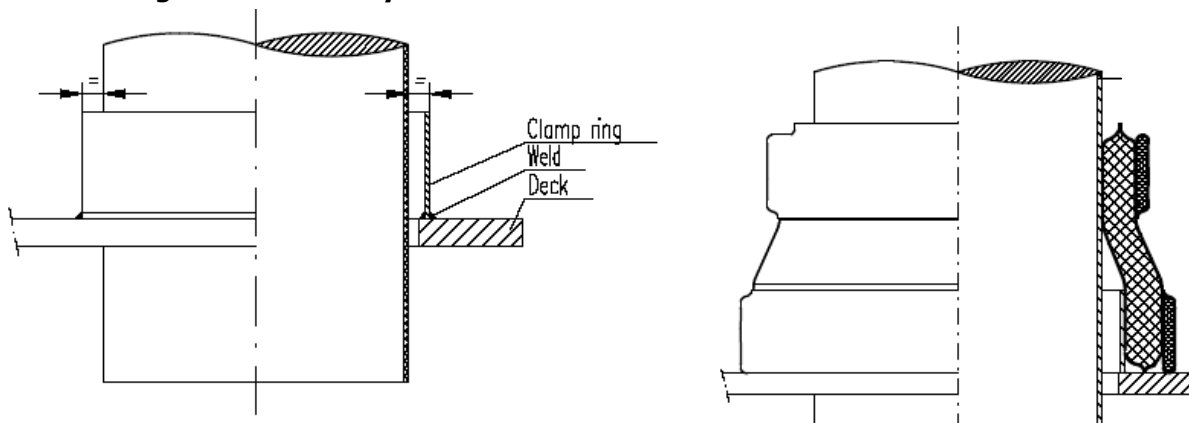

3. Set the compensator to the correct built-in length according to the dimension overleaf.
4. Install the supplied stainless steel (AISI 201) binding around the compensator, through the straps and tighten the binding with the supplied tensioning tool. Carefully follow the instructions supplied with the tool.



5. Check if the compensator can slide along the pipe. If so, the binding should have more tension. Especially the A60 version needs adequate circumferential compression to assure the clamping force.
6. The A60 version fabric compensator should be incorporated in the deck and pipe insulation used as shown in the installation sketch, to assure optimum sealing properties.

3.2 Assembly instructions flanged fabric compensators

1. Weld the flange with threaded holes to the deck. Accurately position the flange as mentioned in the drawing below.
2. For the splitted version: Fold the texture compensator around the exhaust gas pipe.
For the non-splitted version: Situate the compensator and the flanges around the pipe. Jump over step 3 and 4.

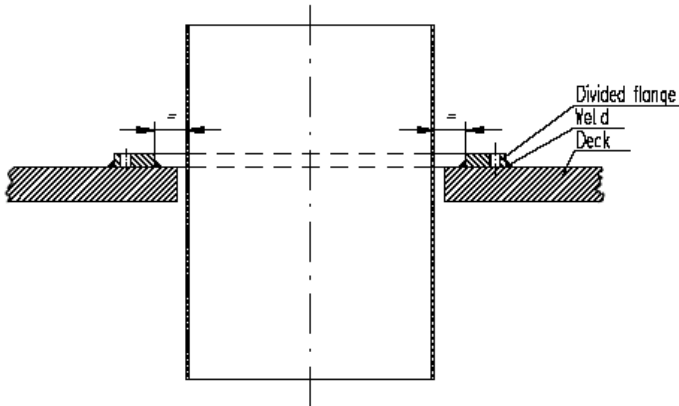

3. Glue the contact surfaces, mentioned with 'P', with the delivered silicone paste and fix them together. Don't touch the glue; use a spatula to spread out the glue.
4. Then glue the contact surfaces, mentioned with 'Q', and fix them together too. Then mount the bolts as mentioned below, and wait twenty-four hours before proceeding to the next step.

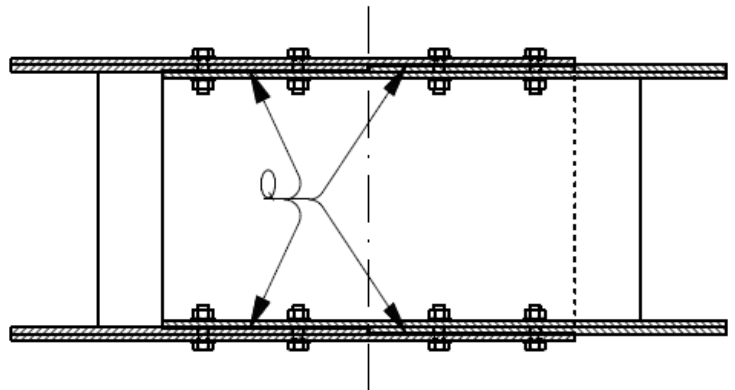
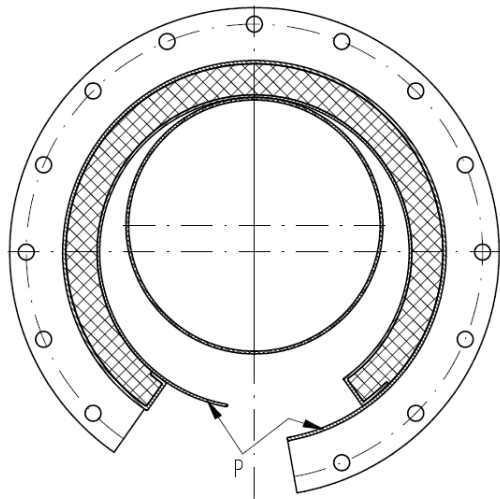

5. For the splitted version: Remove the bolts, used to glue the compensator.
For both versions: Position the splitted flanges and weld them together (use a welding blanket). Assemble the combined flanges as mentioned below. For optimum strength, turn one flange ninety degrees so that the welds are opposite. Pull the fireproof sealed penetration with the flanges to the advised built-in length and weld the upper pipe flange to the exhaust pipe. Please take in consideration the alignment of the holes.

