

### 3.1 Stainless steel exhaust bellows

There are two basic types of expansion bellows – singles and doubles, and their purpose is to absorb the movement in any pipework run that is fixed between two fixed points.

Single bellows units are chiefly used to absorb axial movement, while double units are more suitable where lateral movement is present.

To move a bellows in any direction a force must be applied. That force is the product of the movement and the spring rate of the bellows in the direction of the movement.

Rubber Design supplies a stainless steel bellows with a low stiffness, which achieves in combination with our flexible suspension the best

control of vibrations and forces in pipe systems which provides optimal lifetime.

We can deliver bellows with welding ends or flanges. Standard we can supply flanges like DIN 86044, DIN PN 6/10. (For measurements see attached flange tables), if required we are able to deliver other types of flanges e.g. JIS 5K and ANSI 150 LBS or a flange especially made in accordance with your desires. It is also possible to deliver the stainless steel bellows with a rotating flange to simplify assembling.

#### Single bellows

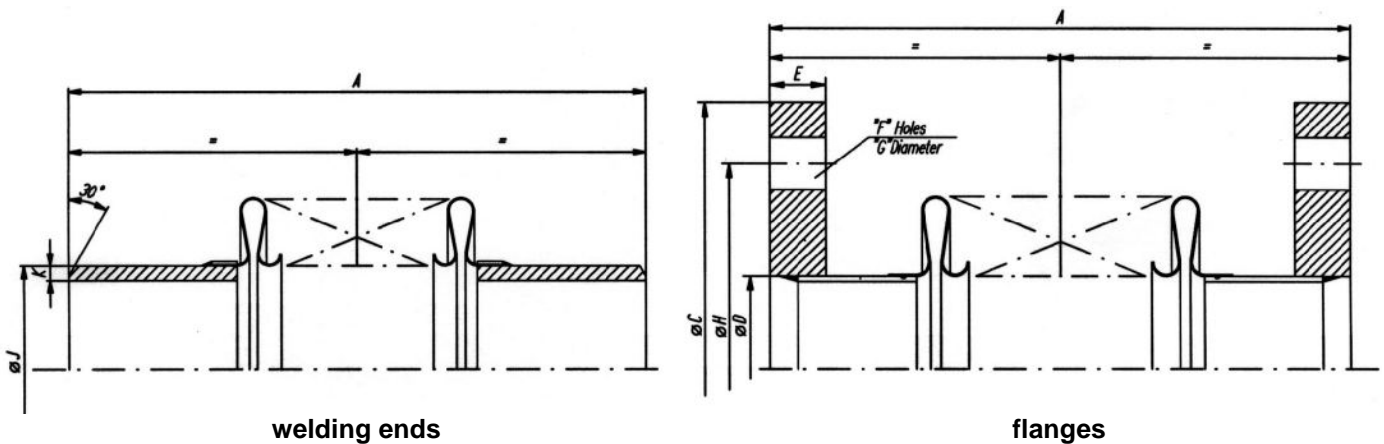

N.B.	050	065	080	100	125	150	200	250	300	350	400	450	500	600	700	800	900	1000
A	195	210	250	290	305	305	310	320	320	330	340	340	340	350	350	350	360	360
J	60	76	89	114	140	168	219	273	324	356	406	457	508	608	-	-	-	-
K	4.5	4.5	4.5	4.5	5.6	5.6	5.6	6.3	6.3	6.3	6.3	6.3	6.3	6.3	-	-	-	-
Max axial	35	38	32	32	32	32	32	40	40	40	64	64	64	64	64	64	64	64
Max lat.	18	16	22	28	22	20	16	17	15	14	13	11	10	9	7.5	7	6	5.5

On page 12, 13, and 14 you can find the dimensions of the standard flanges.  
 Combined movements at reduced rates.



## Cold-pull

Bellows are designed for both compression and extension from their natural or "free length." By pre-setting (or 'cold-pulling') the bellows length prior to installation we are able to take full advantage of the available movement. Maximum performance is obtained by allowing movement to be taken equally either side of the free length position. The mentioned movements for the bellows unit must not be exceeded.

## Transit bars

Some means of length restriction will be added to the bellows unit before shipment in order to maintain the overall length at its' factory setting. These may be threaded bars, angle iron or wood blocks. These must be removed after installation in order for the bellows unit to function correctly.

## Twin bellows

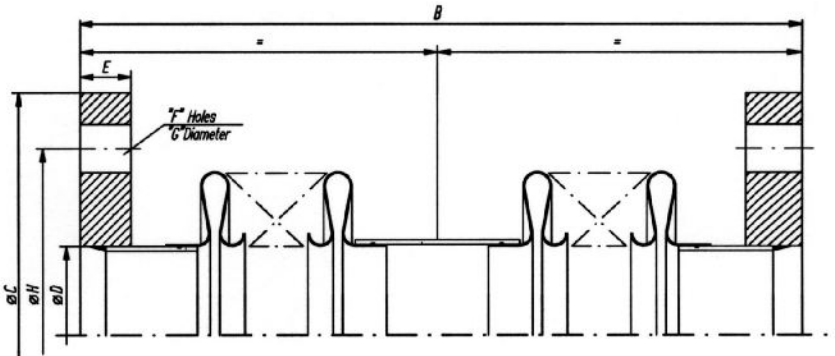

N.B.	080	100	125	150	200	250	300	350	400	450	500	600	700	800	900	1000
B	400	400	400	500	500	500	500	500	600	600	600	600	600	600	600	600
Max axial	80	69	70	75	75	55	64	64	90	90	90	90	90	90	90	90
Max lat.	35	40	60	70	70	32	43	39	75	69	62	52	45	39	35	31

On page 12, 13, and 14 you can find the dimensions of the standard flanges.  
Combined movements at reduced rates

Rubber Design can also deliver counterflanges complete with an exhaust-gasket and a set of nuts, bolts and washers. All kinds of flanges are possible and the gaskets are of high quality Steamgard 500.

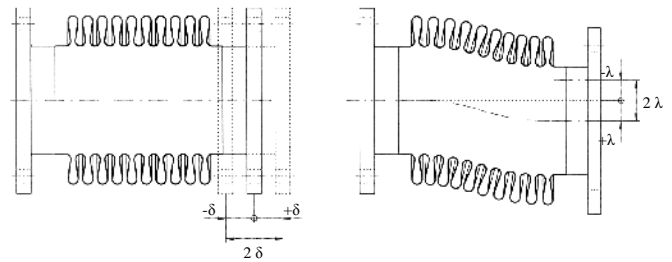

To calculate the maximal axial and lateral movement you can use the following formula.

$$\frac{d_{\max} - d}{d_{\max}} \times l_{\max} = l$$

$$\frac{l_{\max} - l}{l_{\max}} \times d_{\max} = d$$

- $\delta_{\max}$  = Maximal axial movements.
- $\delta$  = Existing axial movements.
- $\lambda_{\max}$  = Maximal lateral movements.
- $\lambda$  = Existing lateral movements.

### 3.2 Flanges type DIN 2573 PN6 with reduced thickness.

Tooling: Inner-, outer- and gasketside rolled.  
 Provided with three gasketgrooves.

Material: Rst. 37-2 or stainless steel.

N.B.	Outside diameter (C)	Inside diameter (D)	Thickness (E)	Number of holes (F)	Diameter of the holes (G)	Pitch circle diameter (H)	Weight (steel)
050	140	61	12	4	14	110	1,1 kg
065	160	77	12	4	14	130	1,4 kg
080	190	90	12	4	18	150	2,0 kg
100	210	116	12	4	18	170	2,2 kg
125	240	142	16	8	18	200	3,4 kg
150	265	171	16	8	18	225	3,8 kg
175	295	195	16	8	18	255	4,5 kg
200	320	222	16	8	18	280	5,0 kg
250	375	276	16	12	18	335	5,9 kg
300	440	327	16	12	22	395	7,9 kg
350	490	360	16	12	22	445	10,3 kg
400	540	411	16	16	22	495	11,3 kg
450	595	461	16	16	22	550	13,1 kg
500	645	512	16	20	22	600	14,1 kg
600	755	614	24	20	26	705	22,0 kg
700	860	716	24	24	26	810	25,8 kg
800	975	818	24	24	30	920	31,8 kg
900	1075	920	24	24	30	1020	35,2 kg
1000	1175	1022	24	28	30	1120	38,1 kg

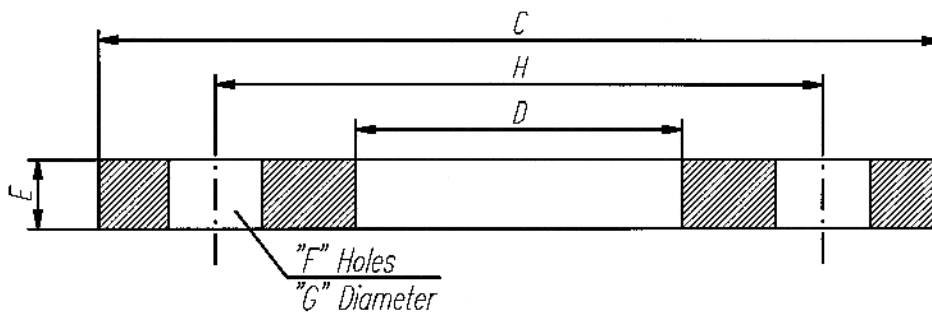

### 3.3 Flanges type DIN 2576 PN10 with reduced thickness.

Tooling: Inner-, outer- and gasketside rolled.  
 Provided with three gasketgrooves.

Material: Rst. 37-2 or stainless steel.

N.B.	Outside diameter (C)	Inside diameter (D)	Thickness (E)	Number of holes (F)	Diameter of the holes (G)	Pitch circle diameter (H)	Weight (steel)
050	165	61	12	4	18	125	1,6 kg
065	185	77	12	4	18	145	2,0 kg
080	200	90	12	8	18	160	2,2 kg
100	220	116	12	8	18	180	2,4 kg
125	250	142	16	8	18	210	3,9 kg
150	285	171	16	8	22	240	4,7 kg
175	315	196	16	8	22	270	5,6 kg
200	340	222	16	8	22	295	6,1 kg
250	395	276	16	12	22	350	7,3 kg
300	445	328	16	12	22	400	8,3 kg
350	505	360	16	16	22	460	14,4 kg
400	565	411	16	16	26	515	17,1 kg
450	615	462	16	20	26	565	18,5 kg
500	670	514	16	20	26	620	21,0 kg
600	780	614	24	20	30	725	26,1 kg
700	895	716	24	24	30	840	32,7 kg
800	1015	818	24	24	33	950	41,0 kg
900	1115	920	24	28	33	1050	44,9 kg
1000	1230	1020	24	28	36	1160	53,4 kg

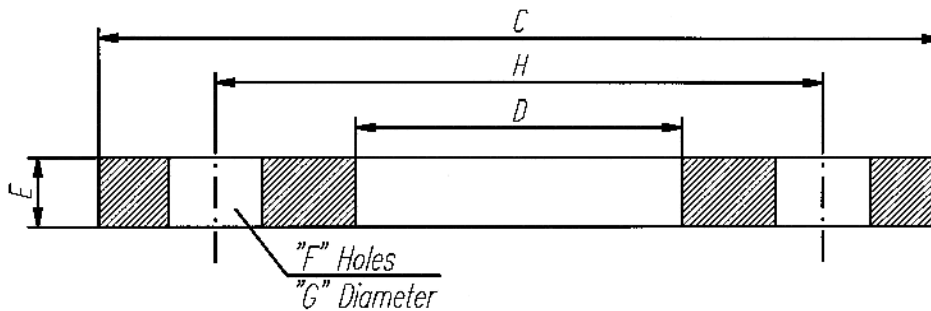

### 3.4 Flanges type DIN 86044

Tooling: Inner-, outer- and gasketside rolled.  
 Provided with three gasketgrooves.

Material: Rst. 37-2 or stainless steel.

N.B.	Outside diameter (C)	Inside diameter (D)	Thickness (E)	Number of holes (F)	Diameter of the holes (G)	Pitch circle diameter (H)	Weight (steel)
050	165	61	12	4	18	125	1,6 kg
065	185	77	12	4	18	145	2,0 kg
080	200	90	12	8	18	160	2,2 kg
100	220	116	12	8	18	180	2,4 kg
125	250	142	16	8	18	210	3,9 kg
150	285	171	16	8	22	240	4,7 kg
200	320	222	16	8	18	280	5,0 kg
250	375	276	16	12	18	335	5,9 kg
300	440	327	16	12	22	395	7,9 kg
350	490	360	16	12	22	445	10,3 kg
400	540	411	16	16	22	495	11,3 kg
450	595	461	16	16	22	550	13,1 kg
500	645	512	16	20	22	600	14,1 kg
550	703	563	20	20	22	650	20,5 kg
600	754	614	20	20	22	700	22,3 kg
650	805	665	20	20	22	750	24,0 kg
700	856	716	20	24	22	800	25,5 kg
750	907	767	20	24	22	860	27,3 kg
800	958	818	20	24	22	900	29,0 kg
900	1060	920	20	28	22	1010	32,3 kg
950	1110	970	20	28	22	1060	34,0 kg
1000	1162	1022	20	32	22	1110	35,6 kg
1100	1266	1126	20	32	22	1210	39,1 kg
1200	1366	1226	20	36	22	1310	42,3 kg
1300	1466	1326	20	40	22	1410	45,5 kg
1400	1566	1426	20	40	22	1510	48,9 kg
1500	1666	1526	20	44	22	1610	52,1 kg

