



DOCUMENTATION SHEET

Conical Mountings

Type RD 214 height re-adjustable

RD 214

Height re-adjustable

General

The aluminium height re-adjustable RD 214 conical mounting has a static load range from 16 kN to 115 kN. The conical design provides high deflection and load capacity combined with long service life. The height re-adjustable RD214 is specially designed when the alignment of the resilient mounted system must be adjusted to prevent vibrations on failure. Although originally designed for main engine, auxiliary engine and generator installations, the mountings are particularly versatile and can be equally used for exhaust gas boilers and silencers. For applications like the suspension of deckhouses, accommodation rooms and control cabins, this mounting is an excellent isolator against structure borne vibration and noise, (passive isolation). The acoustic properties of this type of mounting are excellent. The results of the measured structure borne vibration and noise transmission are available. In both vertical and horizontal directions the transfer functions show a decrease of 12 dB/octave in the low frequency range, an 'ideal mass-less spring characteristic'.

Remark

It is our intention to maintain the excellent standard of our products. Modifications and improvements may be made from time to time, therefore we advise to contact us before ordering.

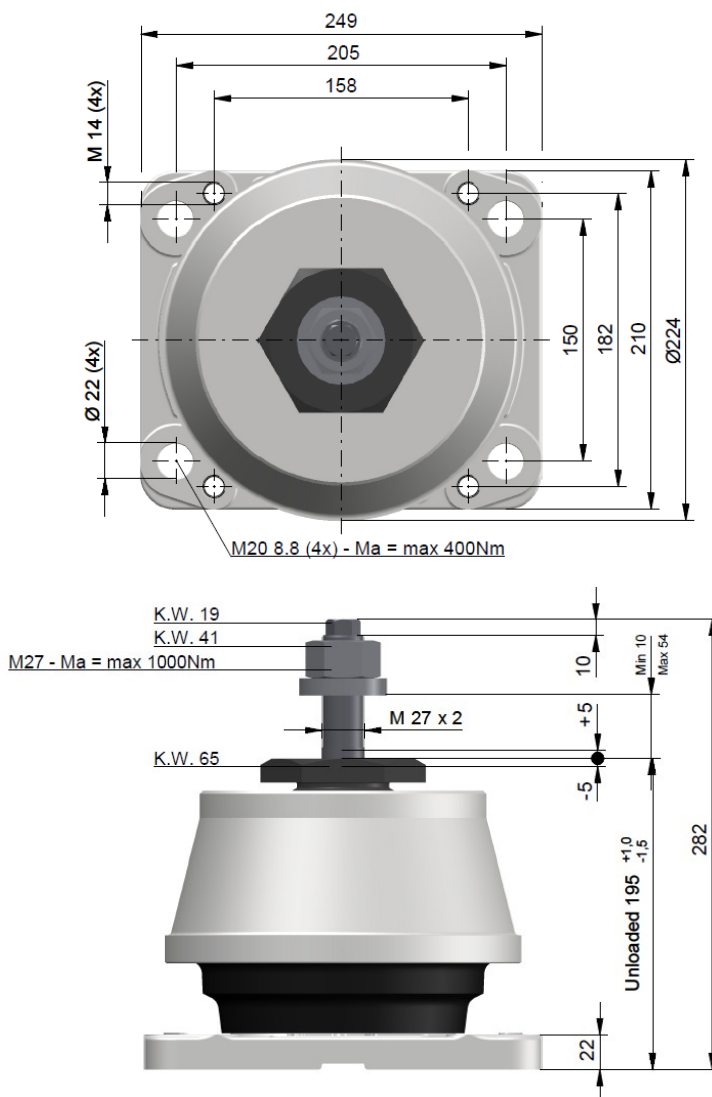

DIMENSIONS

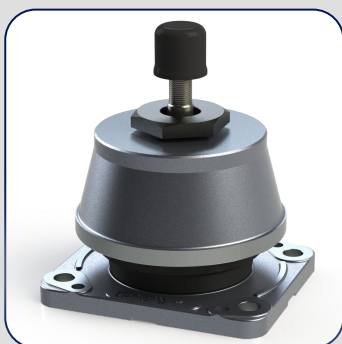



Specification

The characteristics of the mounting are provided by a conical rubber element designed to carry the vertical load in a combination of compression and shear.

The rubber elements are manufactured in six 'standard' rubber mixes: 45NR, 50NR, 55NR, 60NR, 65NR, 70NR and consequently cover a wide range of load / deflection requirements. Applicable up to 70°C continuous and 90°C peak temperatures. Next to that, for the high temperatures applications, there are compounds - 90°C continuous and 110°C peak temperature - and 110°C continuous and 130°C peak temperature available in the above mentioned Shore hardness 's.

The mounting castings are manufactured in a seawater resisting aluminum-silicon alloy. They are designed to protect the rubber element against oil and physical damage. An adjustable central buffer (spindle), manufactured in high tensile steel, controls the mounted equipment displacements due to e.g. ship movements, both vertically and horizontally within defined limits and so eliminates the need for separate buffers. The cut out in the bottom casting allows the buffer adjustment to be checked. All mounting inserts are both individual tested and selected on stiffness by Rubber Design.

Direction	Vertical up	Vertical down	Radial
Displacement limiter clearance [mm]	4	4	3

CLEARANCE

Rubber Hardness [°Sh. A]	45	50	55	60	65	70
Max Marine load [kN]	54	57	64	71	83	95
Max Static load [kN]	60	67	75	85	100	115
Max Static vert. defl. [mm]	15	14,5	14	13,5	12,5	11,5

CHARACTERISTICS

Max Shockload	Contact Rubber Design
---------------	-----------------------

SHOCKLOAD

Mounting selection

The characteristics table is ideal for initial selection; however, it is advisable to seek expert advice before finalizing an installation design. In practice most installations will be subjected to both translational and rotational excitations and in consequence an analysis of all six degrees of freedom will be necessary. We will be pleased to advise on mountings numbers, rubber mix and mounting positions to ensure a 'faultless' flexible mounted installation. Before we can commence the design of a mounting system detailed information is required. Vibration calculations are carried out using our specially developed computer programs to meet new standards for both crews and passengers.



TYPE APPROVALS