



DOCUMENTATION SHEET

Steel Spring Isolators
Installation instruction SO4

INSTALLATION
INSTRUCTION

General

The seismic open steel spring isolator – SO4 consist of the following components:

1. Base casting assembly
2. Steel springs
3. Vertical restraining locking nut
4. Pressure plate
5. Vertical restraining countersink bolt
6. Top casting assembly
7. M20 Washer
8. M20 Nut
9. M20 Leveling screw with spherical machined end

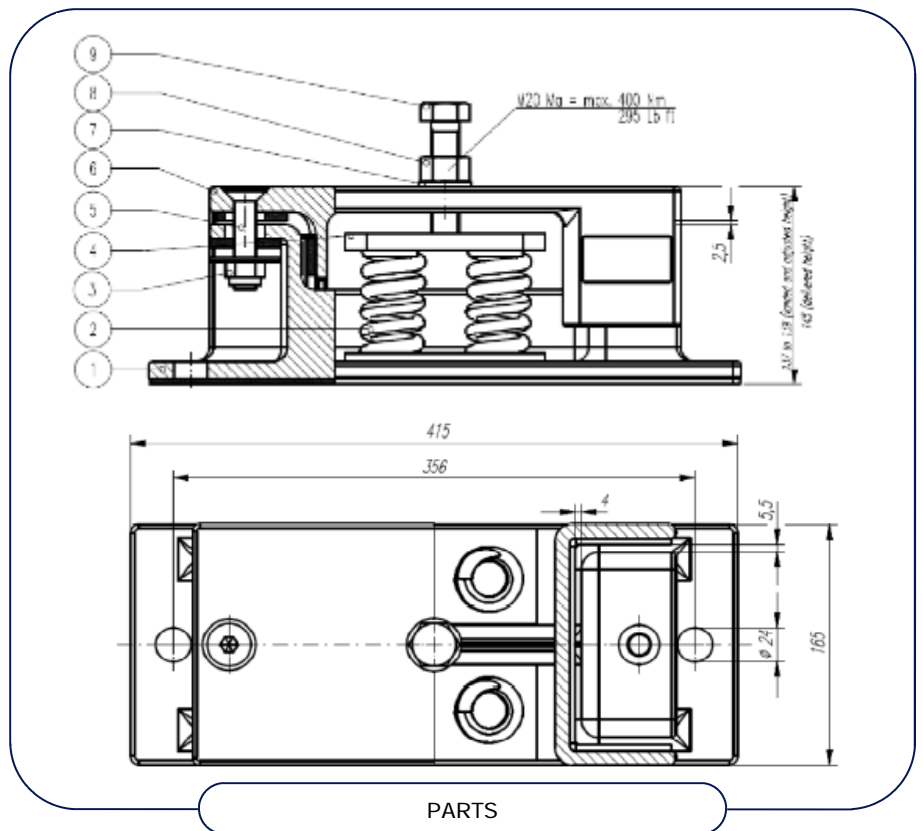

Static deflection

The installation deflection of the steel spring isolator is a result of loading the spring with the weight of the installation. If the installation is lowered onto the steel spring isolator, the steel springs (inside the steel spring isolator) will compress under the static load acting on the steel spring isolator. This static deflection can vary per steel spring isolator and can be calculated by dividing the static load per steel spring isolator by the spring stiffness Cz.

Nominal working height : The nominal working height is the height of the steel spring isolator when adjusted and levelled [fig.1] to provide the best performance of the steel spring isolator.

Aligning of the pressure plate: Before you begin installing the seismic mount check if the blue/black dot on the pressure plate is aligned with the M20 hole. It 's possible that the pressure plate moved during transportation, if so align the dot on the pressure plate with the M20 hole using a nylon hammer.

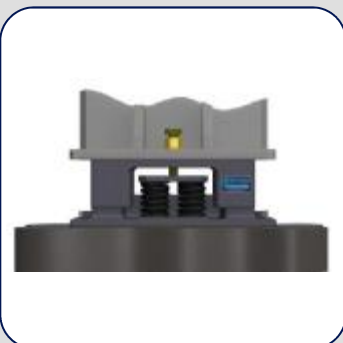



AVM Air Spring Ltd.

A subsidiary of Rubber Design B.V.

Align the Seismic Open isolators on the foundation floor. Before continuing check if the blue or black dot on the pressure plate (4) is aligned with the M20 hole.



We recommend to fixate the Seismic Open isolator using a adequate connection between foundation and base casting.



Lower the installation on the Seismic Open isolator. Ensure that the hole of the base frame is in line with the M20 threaded hole of the top casting.



With the full static load of the installation acting upon the Seismic Open isolator, the steel springs (2) will compress and the top casting (6) makes contact with the base casting (1).

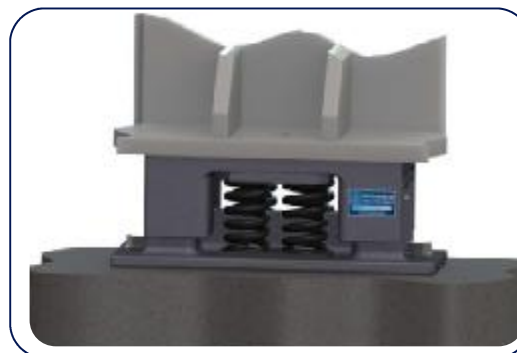

INSTALLATION INSTRUCTION



AVM Air Spring Ltd.

A subsidiary of Rubber Design B.V.

INSTALLATION INSTRUCTION

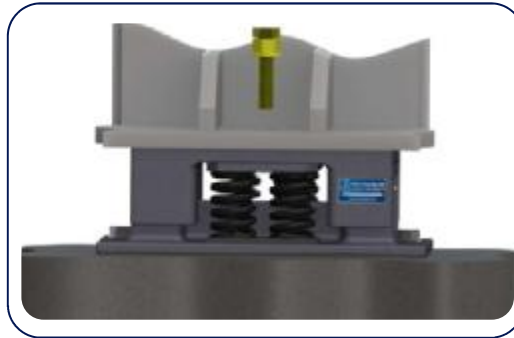

Fit in the M20 levelling bolt with machined spherical end (9). Make sure that the washer (7) and nut (8) are included.

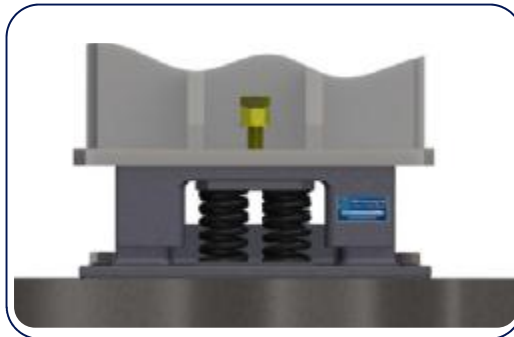

After 7-8 turns the M20 levelling bolt (9) will make contact with the pressure plate (4). When turning the levelling bolt further it compresses the steel springs.

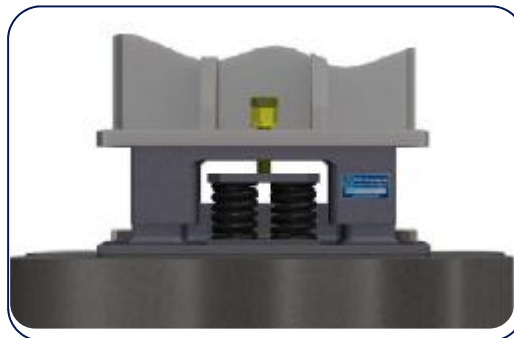

Turn the M20 levelling bolt until the total height of the Seismic Open isolator is 138mm (+/- 1mm). The distance between the top and base should be 2.5mm.

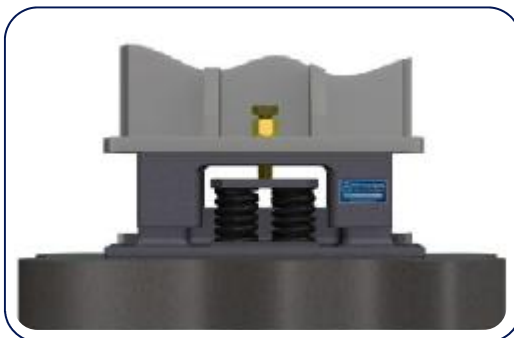

Fix the installation to the Seismic Open isolator by use of the M20 nut. We recommend to use torque wrench with a maximum tightening torque of 400 Newton meters or 295 foot pounds.

AVM Air spring Limited
Unit 2A - Brook Lane Industrial Estate
Westbury - Wiltshire BA 13 4EP
England
Telephone: +44 (0) 1373 85 82 23
Telefax: +44 (0) 1373 85 82 24
WWW: www.avmspring.com
E-mail: info@avmspring.com