



DOCUMENTATION SHEET

Steel Spring Isolator Type CS

CS

General

Circular spring isolators type CR, CS and CM are available for a load range up to 4 kN at 25 mm deflection. The helical spring isolators are enclosed in aluminum castings, the top interlocking with the base. A built-in levelling device is adjustable by the supplied top fixing screw. A molded neoprene O-ring prevents metal to metal contact of the casting and forms a seal against the weather and contaminants. For offshore applications we recommend the use of Admiralty Gun Metal castings, which are available for different types of isolators

Applications

- Generator sets
- Emergency power supplies
- DC-AC converters
- Industrial fans
- Air-handling units
- Pumps
- Air-conditioning machines
- Compressor packages
- Electrical equipment
- Refrigerators
- Cooler units

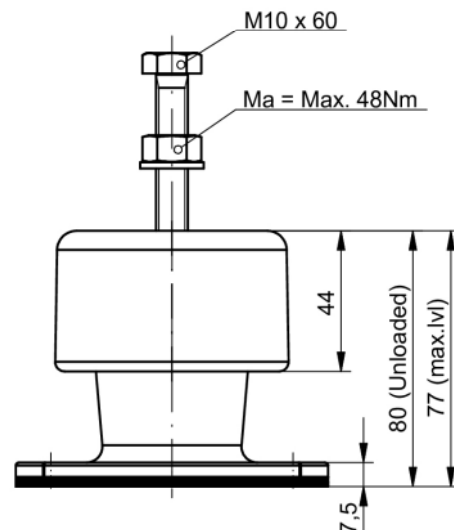
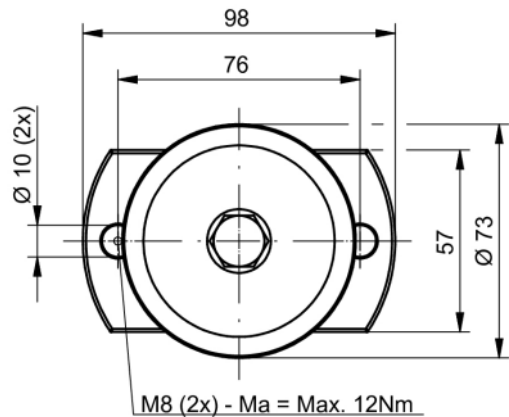

DIMENSIONS





Type	Cz [N/mm]	Cx, y [N/mm] at preferential load	Fz max [N]	Fz preferential [N]
CS35	6,1	2,4	156	136
CS60	10,8	4,2	274	238
CS100	18,3	6,8	464	402
CS150	26,0	9,3	658	570
CS200	35,0	12,1	889	770
CS250	43,8	14,5	1112	963
CS300	52,5	16,4	1333	1156
CS365	63,8	18,3	1620	1404

CHARACTERISTICS

Isolator selection

This described isolator selection is based on the vertical load of the isolators, if required seismic and 6 DOF calculations can be performed by our specialists.

1. Determine the total weight of the machine to be isolated, including work load
2. Determine the position of the combined centre of gravity in horizontal and vertical planes
3. Decide the number of isolators and the positions where the isolators are to be placed relative to the combined centre of gravity
4. Calculate the load per isolator
5. Select with the help of the preferential load in the table the suitable type of mounting

We recommend selection of the isolators be made with the load per isolator within + or - 10% of the preferential load. The static deflection of the isolator is calculated by dividing the load per isolator by the stiffness Cz given in the table for the selected isolator.



Rubber Design B.V.

Industrieweg 21
2995BE Heerjansdam
The Netherlands
Phone: +31 (0)78 677 87 78
Email: info@rubberdesign.nl
Web: www.rubberdesign.nl