



## DOCUMENTATION SHEET

### Steel Spring Isolator Type CT

CT

#### General

Circular spring isolators type CR, CS, CM, CT and CX are available for a load range up to 12.45 kN at 25 mm deflection and up to 10.25 kN at 50 mm deflection. The helical spring isolators are enclosed in aluminum castings, the top interlocking with the base. A built-in leveling device is adjustable by the supplied top fixing screw. A molded neoprene O-ring prevents metal to metal contact of the casting and forms a seal against the weather and contaminants. For offshore applications we recommend the use of Admiralty Gun Metal castings, which are available for different types of isolators

#### Applications

- Generator sets
- Emergency power supplies
- DC-AC converters
- Industrial fans
- Air-handling units
- Pumps
- Air-conditioning machines
- Compressor packages
- Electrical equipment
- Refrigerators
- Cooler units

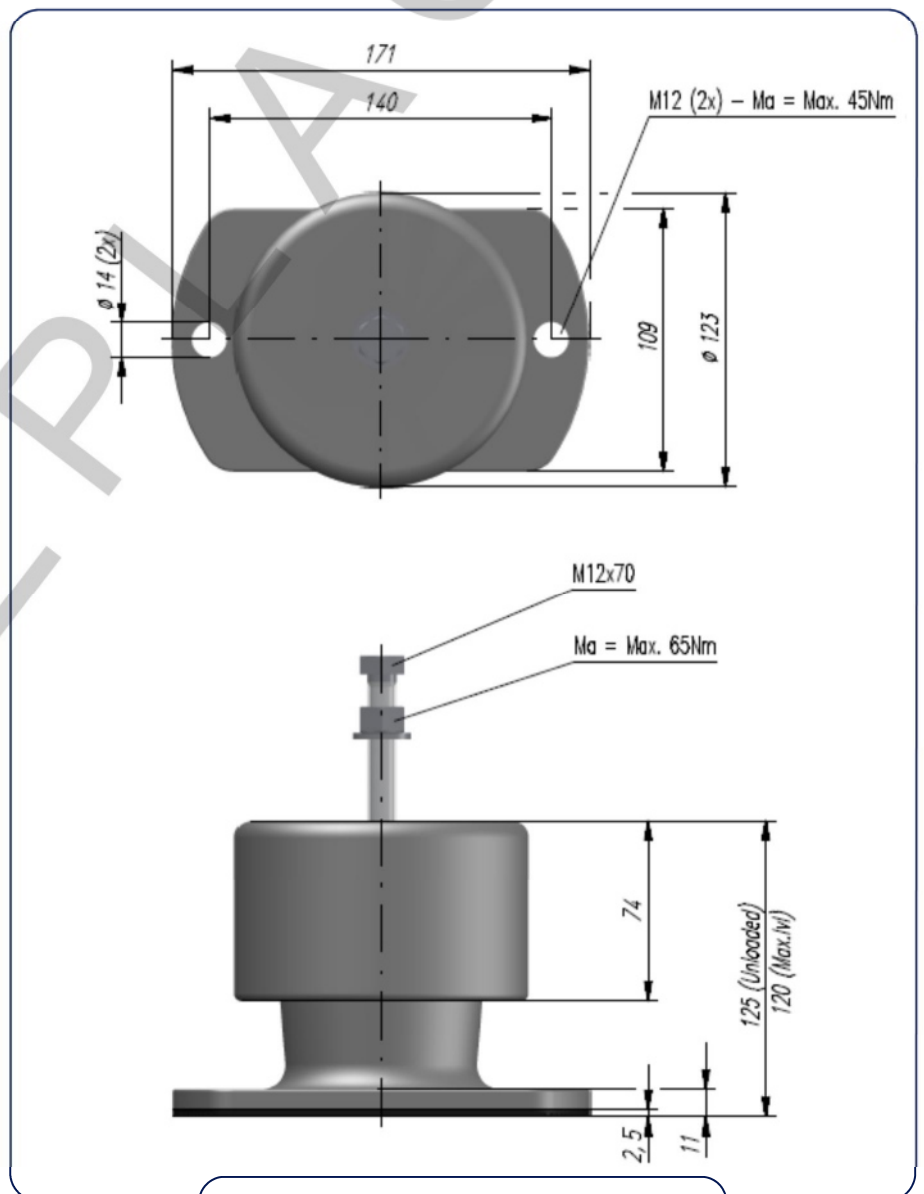
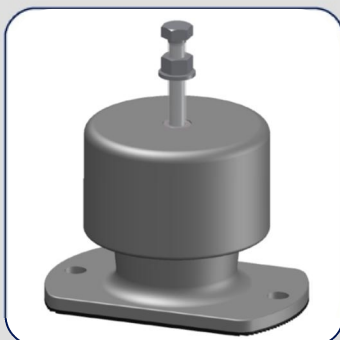

#### DIMENSIONS



Type	Cz [N/mm]	Cx, y [N/mm]		
		at preferential load	Fz max [N]	Fz preferential [N]
CT300	52,5	40,5	1334	1156
CT400	70,1	53,6	1779	1541
CT500	87,6	65,5	2224	1926
CT650	113,8	62,4	2891	2504
CT750	131,4	92,0	3336	2890
CT900	157,6	108,8	4003	3467
CT1000	175,6	119,4	4453	3857
CT1150	201,4	137,2	5116	4431
CT1250	219,2	139,0	5567	4822
CT1320	231,2	141,1	5872	5086
CT1400	252,2	145,7	6406	5548
CT1500	271,4	147,3	6895	5972

CHARACTERISTICS

#### Isolator selection

This described isolator selection is based on the vertical load of the isolators, if required seismic and 6 DOF calculations can be performed by our specialists.

1. Determine the total weight of the machine to be isolated, including work load
2. Determine the position of the combined centre of gravity in horizontal and vertical planes
3. Decide the number of isolators and the positions where the isolators are to be placed relative to the combined centre of gravity
4. Calculate the load per isolator
5. Select with the help of the preferential load in the table the suitable type of mounting

We recommend selection of the isolators be made with the load per isolator within + or - 10% of the preferential load. The static deflection of the isolator is calculated by dividing the load per isolator by the stiffness Cz given in the table for the selected isolator.



#### Rubber Design B.V.

Industrieweg 21  
2995BE Heerjansdam  
The Netherlands  
Phone: +31 (0) 78 677 87 78  
Fax: +31 (0) 78 677 10 38  
Email: [info@rubberdesign.nl](mailto:info@rubberdesign.nl)  
Web: [www.rubberdesign.nl](http://www.rubberdesign.nl)