



## DOCUMENTATION SHEET

### Steel Spring Isolators

### Installation instruction

INSTALLATION  
INSTRUCTION

#### General

The steel spring isolators consist of the following components:

1. Top cover assembly with central threaded insert for the levelling screw
2. Spring pressure plate
3. Steel springs
4. Rubber O-ring damper device
5. Base casting
6. Levelling bolt
7. Locknut
8. Washer

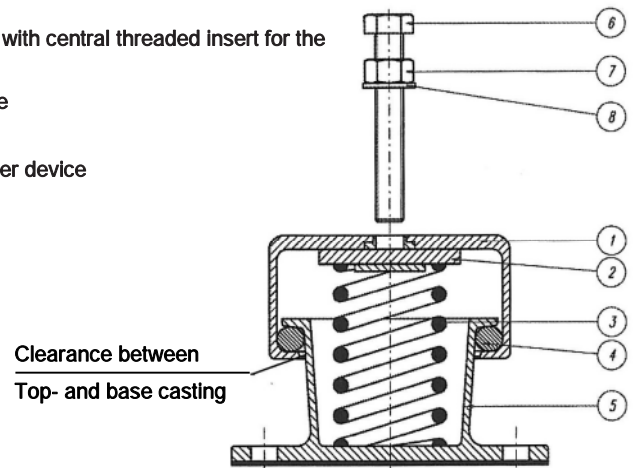

PARTS

#### Static deflection

The static deflection of the steel spring isolator is caused by the weight of the machine. If the machine is lowered onto the steel spring isolator, the steel springs (inside the steel spring isolator) will compress under the static load acting on the steel spring isolator. This static deflection can vary per steel spring isolator and can be calculated by dividing the static load per steel spring isolator by the spring stiffness  $C_z$ .

#### Maximum height

The maximum height or unloaded height, (H) [fig. 4] of the steel spring isolator is the height of the steel spring isolator as supplied. This maximum height must never be exceeded. If the maximum height is exceeded the rubber O-ring is squashed and the steel spring is blocked. This means that the steel spring isolator becomes rigid and is no longer effective as a vibration isolator. The vibrations of the machine will be transmitted through the rigid steel spring isolator into the foundation.

#### Nominal working height

The nominal working height is the height of the steel spring isolator when adjusted and leveled to provide the best performance of the steel spring isolator. Leveling to the nominal working height also brings the rubber O-ring into play. This rubber O-ring reduces the movements of the machine during starting and stopping. The rubber O-ring also prevents metal to metal contact of the castings and forms a seal against weather and contaminants.

#### Installation instructions

Remove the leveling bolt (6), locknut (7) and washer (8) from the steel spring isolators [fig. 1]. The machine can now be lowered onto the steel spring isolators ensuring that the holes in the base frame of the machine are in line with the threaded holes in the top covers of the steel spring isolators.

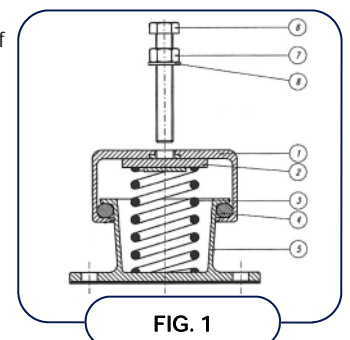
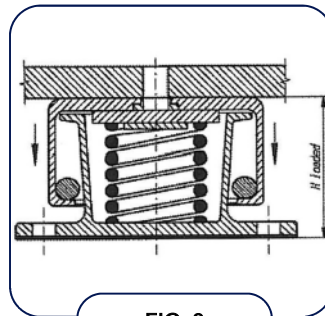

FIG. 1





- With the full static load of the machine acting upon the steel spring isolators, the steel spring isolators will compress as a result of this static load [fig.2]. The load of the machine will be transmitted directly to the steel springs through the top cover ( 1 ) and the pressure plate ( 2 ) .



- The leveling bolts can now be fitted. First make sure that all leveling bolts ( 6 ) have the provided locknut ( 7 ) screwed onto the bolts, followed by the washers ( 8 ) [fig 3]. Screw the leveling bolts through the base frame of the machine into the top cover of the steel spring isolator until resistance is felt. This resistance indicates that the end of the leveling bolt has come into contact with the spring pressure plate.

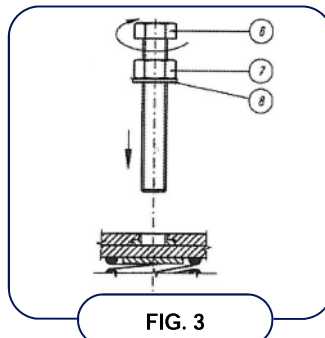

- Further screwing of the leveling bolt will cause the top cover assembly to lift relative to the base casting. As the end of the leveling bolt presses against the pressure plate, the threaded insert in the top cover assembly is being screwed up the leveling bolt, so the top cover, and the machine will begin to rise [fig. 4].

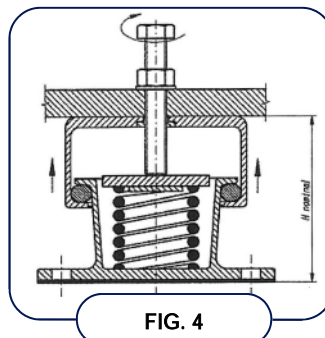

- Lift the steel spring isolator to its nominal working height by screwing down the leveling bolts in equal increments (i.e. 2 to 3 turns per bolt ) at each steel spring isolator. When all steel spring isolators are leveled to their nominal working height, check if the machine is level with a leveling device.

- The steel spring isolator should never be raised above the maximum height stated [table 1]. If the machine needs to be raised above the maximum height of the steel spring isolator, packing shims should be inserted either between the top cover and the machine base frame or underneath the steel spring isolator. If the maximum height is exceeded the rubber O-ring is squashed and the steel spring is blocked (coil bound) . [fig 5] This means that the steel spring isolator becomes rigid and is no longer effective as a vibration isolator. The vibrations of the machine will be transmitted through the rigid steel spring isolator into the foundation.

Steel spring isolator	Unloaded height	Max. levelling height
CR (with base)	53 [mm]	51 [mm]
CR (no base)	61 [mm]	59 [mm]
CS	80 [mm]	77 [mm]
CM	91 [mm]	87 [mm]
MS	94 [mm]	92 [mm]
CT	125 [mm]	120 [mm]
CX	158 [mm]	149 [mm]
LS	128 [mm]	124 [mm]
LR	127 [mm]	127 [mm]
LRX	156 [mm]	156 [mm]

- With the machine leveled, the movement of the machine should be observed during run-up and run-down of the machine. If the movement needs to be reduced, raise the top cover of the steel spring isolator to increase damping. Again this should be carried out by screwing down the leveling bolts in small increments in the correct direction. Raising the top cover reduces the movements as it brings the top cover closer to the rubber O-ring. The higher the steel spring isolator, the more restriction is placed on the spring movement and the movement will be arrested more quickly. The best isolation efficiency will be achieved when the machine can be rocked by hand. When the adjustment of the machine and the steel spring isolators is completed, lock off the leveling bolts by tightening the locknuts and washers down onto the machine base frame.

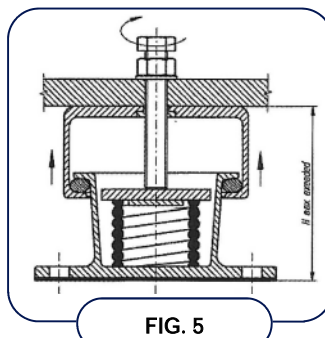

# INSTALLATION INSTRUCTION



**Rubber Design B.V.**  
 Industrieweg 21  
 2995BE Heerjansdam  
 The Netherlands  
 Phone: +31 ( 0 ) 78 677 87 78  
 Fax: +31 ( 0 ) 78 677 10 38  
 Email: [info@rubberdesign.nl](mailto:info@rubberdesign.nl)  
 Web: [www.rubberdesign.nl](http://www.rubberdesign.nl)