



DOCUMENTATION SHEET

Steel Spring Isolator Type SH2

SH2

General

Spring hanger units type SH.1 and SH.2 are designed to support pipelines and will stabilise installations. Placed at the right angle the spring hangers will stabilise the equipment in one plane.

Applications

- Generator sets
- Emergency power supplies
- DC-AC converters
- Industrial fans
- Air-handling units
- Air-conditioning machines
- Compressor packages
- Electrical equipment
- Refrigerators
- Cooler units

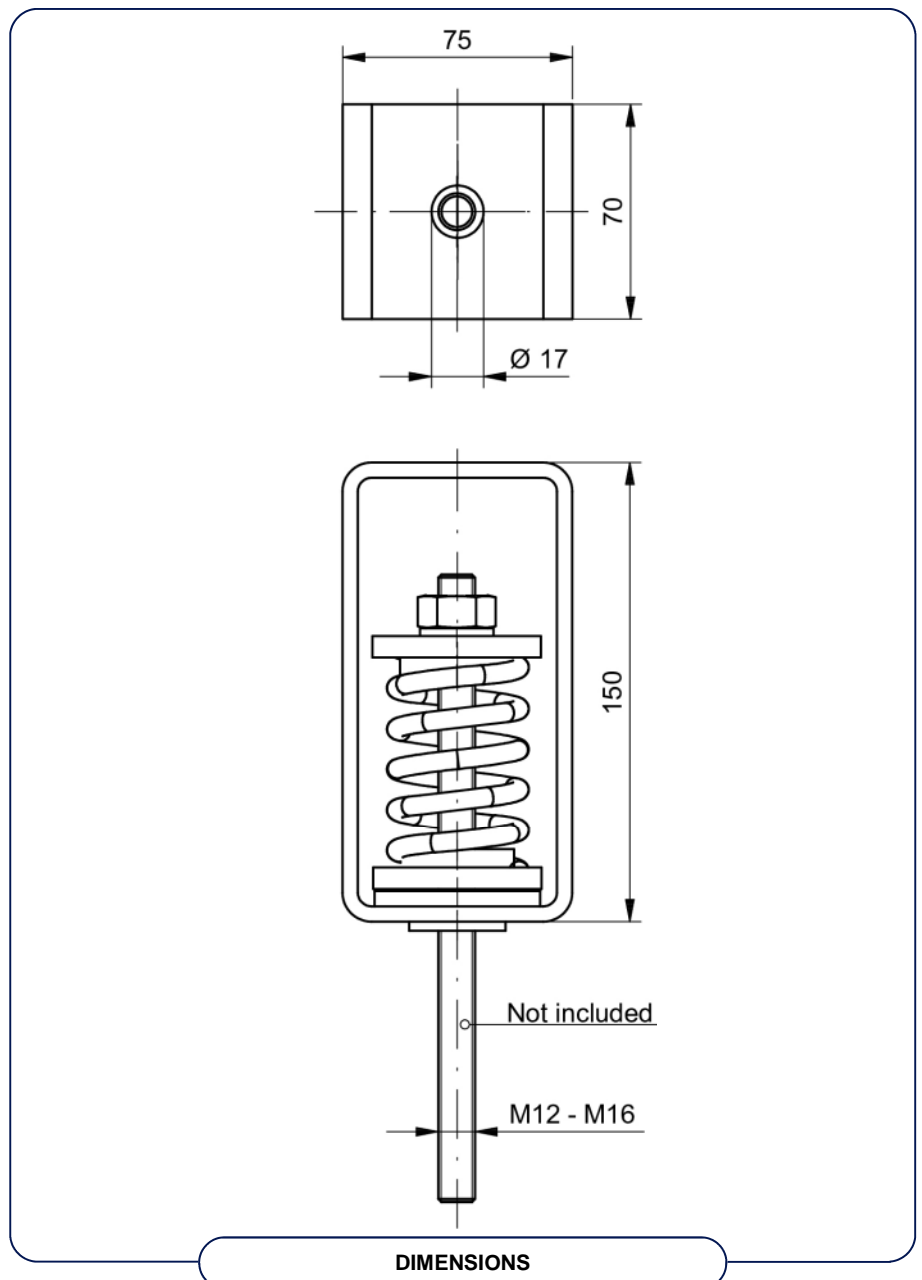



Type	Cz [N/mm]	Cx, y [N/mm] at preferential load	Fz max [N]	Fz preferential [N]
SH2 250	46,2	Depending on rod length	1174	1010
SH2 350	61,3	Depending on rod length	1557	1339
SH2 450	79,5	Depending on rod length	2019	1737
SH2 550	96,3	Depending on rod length	2447	2104
SH2 650	114,9	Depending on rod length	2918	2510
SH2 750	131,3	Depending on rod length	3336	2869

CHARACTERISTICS

Isolator selection

This described isolator selection is based on the vertical load of the isolators, if required seismic and 6 DOF calculations can be performed by our specialists.

1. Determine the total weight of the machine to be isolated, including work load
2. Determine the position of the combined centre of gravity in horizontal and vertical planes
3. Decide the number of isolators and the positions where the isolators are to be placed relative to the combined centre of gravity
4. Calculate the load per isolator
5. Select with the help of the preferential load in the table the suitable type of mounting

We recommend selection of the isolators be made with the load per isolator within + or - 10% of the preferential load. The static deflection of the isolator is calculated by dividing the load per isolator by the stiffness Cz given in the table for the selected isolator.

Rubber Design B.V.

Industrieweg 21

2995BE Heerjansdam

The Netherlands

Phone: +31 (0)78 677 87 78

Email: info@rubberdesign.nl

Web: www.rubberdesign.nl